



APM TECHNOLOGIES

PROFESSIONAL INNOVATIVE BRANDING SERVICE

www.apmtech.cn

Programmable Switching Power Supply User Manual >>>



■ ENGLISH: PAGE 1

■ 中文：起始页 95

Contents

Preface	4
Safety Notices	5
1 About this Manual	6
1.1 Scope	6
1.2 Targeted Audience	6
1.3 Use of this Manual and Legal Notices	6
2 Unpacking	7
2.1 Packing List	7
2.2 Checking for Shipping Damage	8
3 Products Introduction	8
3.1 Product Description	8
3.2 Product Features	9
3.3 Operation Instructions	9
3.4 Operation Environments	9
3.5 Product Storage	10
3.6 Maintenance and Cleaning	10
3.7 Power Supply Voltage	10
3.8 Fuse	10
3.9 Warm-up Time	11
3.10 Unit Shutdown	11
3.11 Operation Precautions	11
3.12 Starting Procedure	11

4 Operation	13
4.1 Front Panel Description	13
4.1.1 Description of Functional Keys	13
4.1.2 Description of Multifunctional Keys	14
4.1.3 Introduction to Front Panel Operations	14
4.1.4 Front Panel Operations	14
4.1.5 Store and Recall Operation	15
4.1.6 Menu Operation	15
4.1.7 SYSTEM SETTING	17
4.1.8 OUTPUT SETTING	24
4.1.9 INFORMATION	26
4.1.10 PROTECTION Setting	26
4.1.11 SERIES/PARALLEL Setting	30
4.1.12 TIME CONTROL	33
4.1.13 SPECIAL TEST FUNCTIONS	34
4.1.14 ADDITIONAL FUNCTIONS	39
4.2 Rear Panel	40
4.2.1 Input Connections	41
4.2.2 Load Connections	44
4.2.3 Remote Compensation	45
4.2.4 DVM Function	46
5 Applications	47
5.1 External Setting	47
5.2 Timer Control Function	47
5.3 SHORT MODE Function	48
5.4 Master-slave Mode Configuration	49
5.5 List Function	50

6 SCPI Communication Protocol	52
6.1 SCPI Order Description	52
6.1.1 IEEE-488.2 Common Order	52
6.1.2 Orders Specified by APM's Programmable DC Power	52
7 Introduction to Software	60
7.1 Software Installation	60
8 Troubleshooting	61
9 Installation	62
9.1 Product Dimensions	62
9.2 Shelf Mounting Diagram of DC Power Supply	62
9.3 Assemble Rack Mount Brackets	63
10 Recycling and Disposal	63
11 Contact Us	63
Appendix A Specifications	64
Appendix B Web Server	88
Appendix C Warranty	92

Preface

Dear Customer,

Thank you for using this series Programmable Switching Power Supply, a product developed & manufactured by APM Technologies. We sincerely hope that this product will meet your needs.

The sections outlined in this user manual are suitable for the following product models:

<div style="display: flex; align-items: center;"> <div style="margin-right: 5px;">□</div> <div style="margin-right: 5px;">○</div> <div style="margin-right: 5px;">Power</div> </div> <div style="display: flex; align-items: center;"> <div style="margin-right: 5px;">□</div> <div style="margin-right: 5px;">○</div> <div style="margin-right: 5px;">Voltage</div> </div>	1U Units					2U Units			
	600W	1000W	1200W	1500W	1600W	1000W	2000W	3000W	4000W
20VDC	-	-	-	-	-	200A ^[1]	200A	200A	200A
32VDC	-	-	-	-	-	-	-	120A	-
40VDC	-	-	-	-	-	120A ^[1]	120A	120A	120A
60VDC	-	-	-	-	-	-	-	-	-
75VDC	-	-	-	-	-	50A ^[1]	50A	50A	60A
80VDC	-	-	-	-	-	-	60A	60A	-
120VDC	-	-	-	-	-	40A ^[1]	40A	40A	40A
150VDC	10A ^[2]	10A ^[2]	10A ^[2]	10A ^[2]	-	30A ^[1]	30A	30A	30A
200VDC	8A ^[2]	8A ^[2]	8A ^[2]	8A ^[2]	-	24A ^[1]	24A	24A	24A
400VDC	7.5A ^[2]	7.5A ^[2]	7.5A ^[2]	7.5A ^[2]	-	15A ^{[1][2]}	15A ^[2]	15A ^[2]	15A ^[2]
600VDC	5A ^[2]	5A ^[2]	5A ^[2]	5A ^[2]	-	10A ^{[1][2]}	10A ^[2]	10A ^[2]	10A ^[2]
800VDC	4A ^[2]	4A ^[2]	4A ^[2]	4A ^[2]	-	7.5A ^{[1][2]}	7.5A ^[2]	7.5A ^[2]	7.5A ^[2]

Model guide

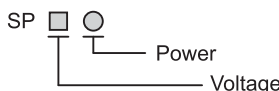

For example: SP200VDC1500W
Note: SP stands for Switching Power.

^[1] Model guide

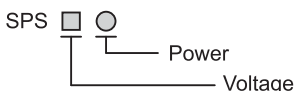

^[2] For these models, the DVM and Analog input functions is optional.

Issue D (2017-6)

This issue is the forth English and Chinese versions official release, with modification of the specification.

Safety Notices



Warning!

This symbol highlights operations that have the potential to endanger users, operation procedures and instructions must be absolutely understood before use.



Caution!

This symbol highlights precautions users need to take to avoid potential injury during equipment operation.



Note

This symbol highlights important instructions that need to be read before using the equipment.



This symbol indicates of high voltage risk aspects of the product or its use.



This symbol indicates parts that may be at a high temperature. Please do not touch this part of the equipment to prevent scalding.



This symbol indicates that a grounded condition is required before operating the equipment; the terminal with this label must be grounded to prevent electric shock.

About this Manual

1.1 Scope

This manual provides the reader with detailed product information as well as installation, operation and maintenance instructions. This manual also provides our company contact information so that you can tell us your suggestions and comments about the performance of our products in order that we can continue to improve our product quality and our level of service.

1.2 Targeted Audience

This manual is intended for product users and technical personnel that are involved with installing, operating and maintaining the product. Readers are required to have a certain degree of electrical and mechanical knowledge and be familiar with basic electrical and mechanical schematics.

1.3 Use of this Manual and Legal Notices

All materials (including but not limited to graphics, logos, symbols, data, etc.) in this manual are owned by the APM Technologies. No part of this manual can be reproduced without prior authorization from APM Technologies.

The content of this manual will continue to be updated and revised as inevitably there are slight discrepancies or errors. Please check for updates at www.apmtech.cn and download the latest version of this manual and information.

It is prohibited in any way to use all or part of the firmware or software developed by APM Technologies for other commercial purposes. It is prohibited to decompile, decrypt or otherwise damage the software developed by APM Technologies.

2 Unpacking

2.1 Packing List

Item	Descriptions	Quantity	Remarks
A	Programmable DC Power Supply	1	As ordered
B	Rack Mount Brackets [1]	2	Standard
C	Input Terminal Cover Box [1]	1	Standard
D	Screws [1]	8	Standard
E	Power Cord (In line with the region use)	1	Standard
F	Power Cord with Plug	1	Standard for 600W units
G	RS-232 Communication Cable	1	Standard
H	LAN Communication Cable (568A-568B)	1	Standard
	LAN Communication Cable (568A-568A)	1	Standard
I	USB Communication Cable	1	Standard
J	GPIB Communication Cable	1	Optional
K	Current Sharing Cable	1	Standard
L	System Bus Communication Cable	1	Standard
M	Quick Guide	1	Standard

[1] only individually packaged for 2U units.

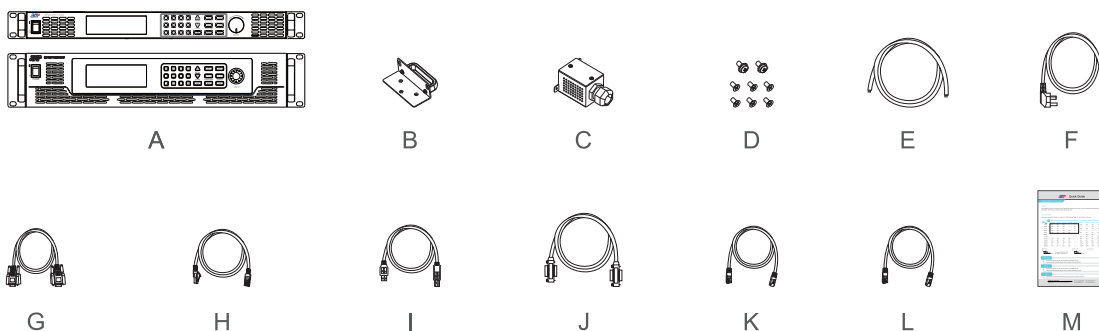

2.2 Checking for Shipping Damage

All APM Technologies Company products have undergone stringent testing before delivery, but inevitably damage can happen during transportation. Once you receive the product, please immediately check if there is any packaging damage that may indicate damage to the product. If you find damage related to product delivery, please immediately notify the transport company. Make sure to take photos documenting the damage to the product, and send them to us so that we can provide you with the best service.

3 Products Introduction

3.1 Product Description

The SP Series DC Power Supplies with single outputs, 1U/2U (rack unit) high, switching power supplies.

With a 16-bit D/A, 24-bit A/D sampling circuits to achieve voltage resolution of 1.5mV and the current resolution of 1mA.

All models have parallel master/slave operation capability with active current sharing, which allows parallel connection of units with accurate current sharing. As well as series connection of up to four units.

The front panel settings allow users to easily set up the output parameters, over voltage protection (OVP), over current protection (OCP), and over power protection (OPP) levels, and preview the settings.

Additionally, the power supplies provide a memory space of 50 instrument settings that can be recalled, as well as a memory space of 10 instrument settings that can be recalled directly.

The rear panel includes the necessary connectors to control and monitor the power supply operation by analog signals or by the built-in remote communication interfaces.

3.2 Product Features

- Worldwide input voltage range, high power density.
- Master/slave parallel & series operation modes for up to 10 units.
- Precision voltage and current measurement via high-speed programmable interface.
- Optically coded knob and multi-function keyboard allow programming Constant Current (CC) and Constant Voltage (CV) modes.
- Voltage rate of rise and drop functions.
- Programmable multi-step settings for output voltage, current, Over Voltage Protection (OVP), Over Current Protection (OCP), Over Power Protection (OPP), and thermal protection (OTP).
- USB / LAN / RS485 / RS232 interfaces using SCPI standard communication protocol.
- Standard analog external remote inputs.
- Remote voltage sensing inputs to compensate for voltage drop to the load.
- Independent DVM output measuring function with inputs.

3.3 Operating Instructions

This product is a precision instrument, please read this manual carefully before use. In order to ensure measurement accuracy it is recommended that a calibration check be performed on this product every year.

3.4 Operating Environments

1. These power supplies must be used in a clean and dry laboratory or testing environment with an ambient temperature of between 0°C and 40°C and a relative humidity of between 10% and 90%.
2. Do not prolong the use of this power supply in a high temperature ambient.
3. Fans cool the power supply by drawing air through the front and exhausting it out the back. Please assure that 20 cm space is present at the front and back of the unit for adequate air circulation.
4. Do not operate this product in an environment that contains large amounts of dust, is subject to strong shock and vibration, is in intense direct sunlight or contains corrosive gases.

3.5 Product Storage

Please store this product in an area with a temperature between -20 °C and 70 °C and with a relative humidity of between 0% and 90% non-condensing. If the product is not in use for a long time, please keep it in the original carton or other similar packaging and store it in a cool & dry place.

3.6 Maintenance and Cleaning

Before cleaning, you must disconnect the input power cord of this power supply. Using a brush or sponge, gently wipe off any dust from the units exterior. To clean the products exterior use only a small amount of non-aqueous cleaning solution such as isopropyl alcohol on a clean cloth. Do not use a corrosive or abrasive cleaning solution to clean this product. The display front panel can be cleaned with gauze damped in soft detergent. Cleaning of dust from the interior of this product must be carried out with a low pressure air gun, and we prefer that such a clean work be performed by an authorized dealer on behalf of the user.

3.7 Power Supply Voltage

Make sure that the AC input voltage is within the product's operating specification before plugging in or connecting to the source, and that the power switch is in the OFF state.



Caution!

- The protective safety earth/ground connection must connect first and disconnect after the AC line and neutral wires. All approved AC power connectors are designed to meet this requirement. If the input wires are directly connected to an AC mains circuit assure that the AC source is deactivated prior to making or disconnecting the connection.

3.8 Fuse

The AC mains fuses installed inside the product are designed to protect the input from major failures, and should not fail under normal operating conditions. Therefore, any sign of fuse failure is an indication that other part(s) of the product is damaged. If fuse melting happens, we recommend that the product be sent back to us for repair.



Warning!

- No user serviceable components enclosed. Do not disassemble the power's enclosure /case to replace the fuse, as there is a danger of sustaining an electric shock.

3.9 Warm-up Time

Once the power supply is switched on, all features of the unit are operable after the start routine has completed. However in order to achieve the specified operating accuracy, please allow the power supply to operate for a warm-up time of 30 minutes.

3.10 Unit Shutdown

When you no longer need to use this product, please make sure the front panel power switch is set to the “OFF” state. After the AC power is switched off the internal fan will continue to run for a few seconds to allow the internal capacitors to discharge. When discharging is completed, the unit will automatically shut down.

3.11 Operation Precautions

1. When the unit is first turned on the DC output is in a deactivated state. It can be activated by pressing the output turn on push button on the front panel or by remote control command.
2. Before turning on the DC power output, check that all the setting values of the power supply are in accordance with the load requirements.

3.12 Starting Procedure

Plug in the DC power and turn on the power switch on the front panel, the programmable DC power supply will execute a self-checking routine:

The company name APM Technologies will appear on the front panel display:

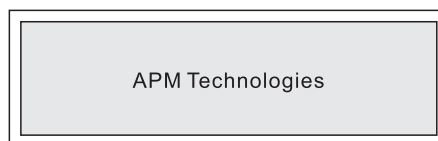

After 1 second, it enters the self-testing (self-checking) mode;

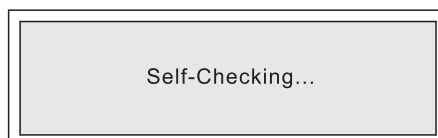

The power supply firmware will perform a series of tests checking memory, communications and other functions. When the self-checking procedure is completed, the front panel display will automatically display the main screen:

00.0000V	00.0000A	CV
00.0000V	00.0000A	

The first row will display the internal voltage measured value, current measured value and the operating mode of the programmable DC power. The second row will display the voltage setting value and the current limit setting.

Press down the **Shift** + **Display** keys simultaneously to entering the following menu:

00.0000V	00.0000A	CV
00.0000V	0000.00W	35°C

The first row will display the output voltage terminals measured value, current measured value and the operating mode of the programmable DC source. The second row will display the unit's DVM measured value, output power and internal temperature. Press the **Display** key to return to the main page.

4 Operation

4.1 Front Panel Description

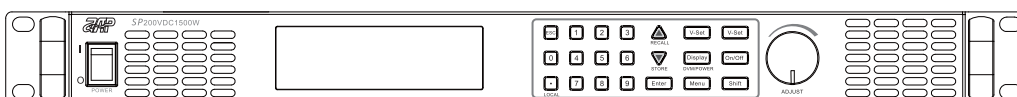



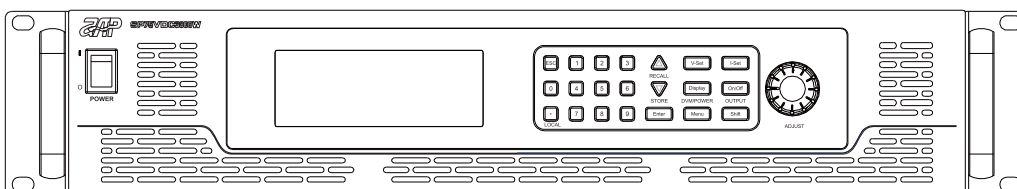









SP200VDC1500W Front Panel



SP75VDC3000W Front Panel

4.1.1 Description of Functional keys

Keys	Descriptions
	Number keys.
	Decimal point key.
	Escape key.
	Up key, for selecting menus or to increase the set value.
	Down key, for selecting menus or to decrease the set value.
	Confirm key.
	To set the value of the output regulation voltage.
	To set the value of output current limit.
	Press to return to main display.
	To turn the output of programmable DC source On or Off.
	To enter function setting items.
	Used in conjunction with multi-function key for more selections.

4.1.2 Description of Multifunctional Keys

Keys	Descriptions
LOCAL	To select front panel operation.
RECALL	To recall settings of programmable DC source from the memory storage.
STORE	To store the current settings of power supply.
DVM/POWER	To display DVM reading and output power.

4.1.3 Introduction to Front Panel Operations



Note

- The Default setting values will be used if setting values are not saved before restart.
1. Front panel **On/Off** key is used for turning the power supply On and Off.
 2. Operating modes include Front Panel operation mode, Remote operation mode and External operation mode, the first two can be switched by a connected computer and the operating mode can be changed without affecting the power supply output.
 3. All front panel keys are functional when the power supply is in Front Panel operation mode.
 4. Under remote operation mode, all Front Panel keys except the decimal point key are locked.

4.1.4 Front Panel Operations

4.1.4.1 Voltage Setting

Output voltage (CV MODE): Assure that the current setting is greater than the expected load current to maintain the output in CV mode, otherwise the output voltage will not be equal to the Output Voltage setting. There are two setting modes:

Option One (use key):

1. Set voltage value by **V-set** + **0** + **9** + **Enter**.
2. Press **On/Off** key to turn on the output.

Option Two (use knob):

1. Press on the key **V-set**.
2. Please note that pressing the control knob will move the cursor to a different digit, and then turning the knob changes this digit value to increase or decrease the setting. Press the **Enter** key to finish the setting.
3. Press the **On/Off** to turn on the output.











00.0000V	00.0000A	OFF
00.0000V	00.0000A	

4.1.4.2 Current Limit Setting





Current limit setting (CC MODE): assure that the voltage setting is greater than the desired load voltage to maintain the output in CC mode. If the output current limit setting is not equal that desired press the  key, and adjust the setting using a procedure similar to that of the voltage setting.

00.0000V	00.0000A	CV
00.0000V	00.0000A	

4.1.5 Store and Recall Operation



The user can store in non-volatile memory setting parameters that are commonly used, such as: voltage set value, the current set value, and keep them in 50 groups so that they can be recalled for later use. Store the parameters by pressing  +  +  ~  +  . You can remove the parameters from the specified storage area by pressing  +  +  ~  +  .

4.1.6 Menu Operation

The menu structure is designed to be navigated easily by using a few of the front panel keys. The menu options of a particular page can highlighted by using the   keys. The  key is then used to select the highlighted menu option and the next sub menu page is then displayed. One can always return to the previous page by pressing the  key.

All the function setting items are shown in the table below.

Menu	Description
1. SYSTEM SETTING	To set system parameters.
2. OUTPUT SETING	To set the output parameters.
3. INFORMATION	To display the software version, power rating and other information.
4. PROTECTIONS	To set the protection settings.
5. SERIES/PARALLEL	To select Series or Parallel connection modes.
6. TIMER CONTROL	To set automatic operation timer.
7. SPECIAL TEST FUNC	To set special function test.
8. ADDITIONAL FUNCTIONS	Functions that are customizable by the user.

From the main display page press the  key to display the top page of the functions menu. Press the  key to scroll down the menu.

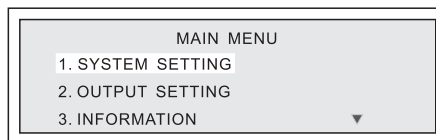

When you press the  key third time the next part of the functions menu will be displayed.

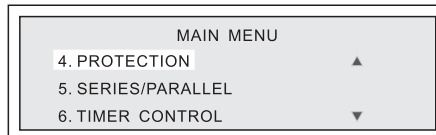

The third page can be displayed in a similar manner.

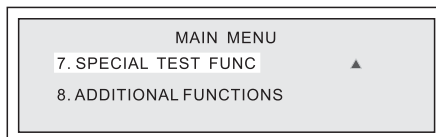

Press the  key to select any of the highlighted menu items.

4.1.7 SYSTEM SETTING

Highlight the SYSTEM SETTING item and press **Enter** to select. The system setting sub-menu will be displayed.

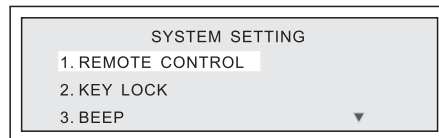

1. REMOTE CONTROL

This menu is for setting the parameters of the remote communication interfaces which include RS232, RS485, USB, LAN.

RS232

Press **Enter** key to enter the remote control menu:

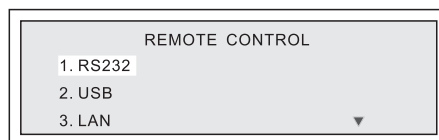

After selecting the communications interface type using the **▲▼** and then **Enter** keys, the user can change the communication parameters.

For example after selecting RS232 type the following sub menu will be displayed:

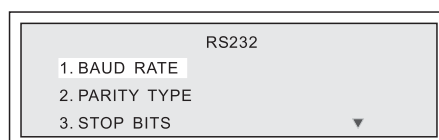

Highlight 1. BAUD RATE and press the **Enter** key to access the following sub-menu:

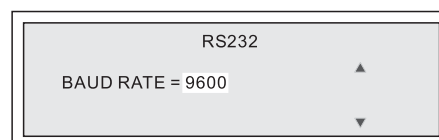

Then you can choose BAUD RATE, including 9600 (default), 19200, 38400, 57600; PARITY TYPE and STOP BITS can be set in a similar fashion as above. PARITY TYPE, including None (default), Odd, Even; and STOP BITS, including 1 (default), 2.

USB

Highlight USB and press the **Enter** key to access the following sub-menu:

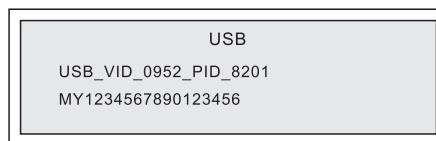

LAN

Highlight IP ADDR and press the **Enter** key to access the following sub-menu:

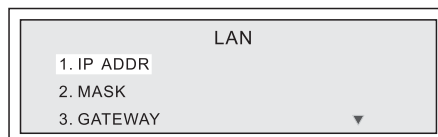

Set the parameters by pressing the **0** ~ **9** + **Enter** keys.

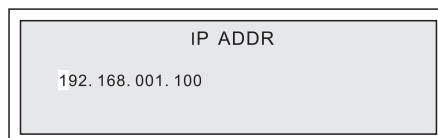

MASK and GATEWAY setting can be set in a similar fashion as above, and press the number key to choose the Address for the unit of between 000 and 255.

Press the **▽** key to select 4. LISTEN PORT. Set the LISTEN PORT of the power supply by pressing the **0** ~ **9** + **Enter** keys.

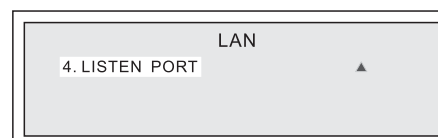

RS485

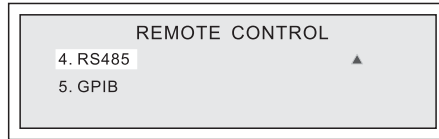

Highlight RS485 and press the **Enter** key to access the following sub-menu:

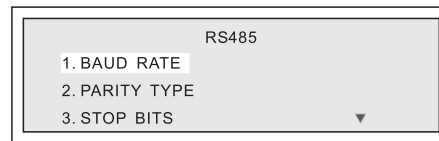

BAUD RATE, PARITY TYPE and STOP BITS setting can be set in a similar fashion as RS232's.

Press the **▽** key to select 4. RS485 ADDR.

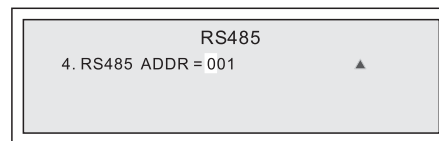

Press the number keys to choose the Address for the unit of between 001 and 254.

The power supply can use RS485 to provide multi-units series connection function for up to 30 units. Set each unit with a different address and add a 120 ohm resistor terminal in the last unit as shown in the below figure.

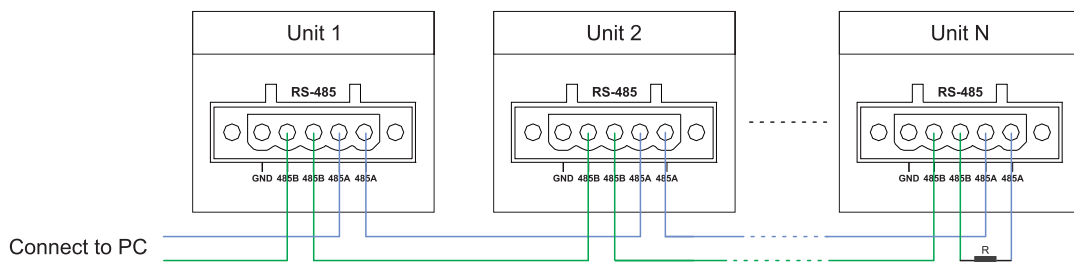

GPIB

Highlight GPIB and press the **Enter** key to access the following sub-menu:

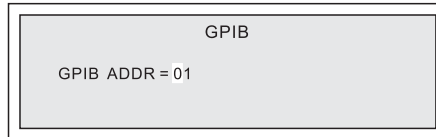

Press the number keys to choose the Address for the unit of between 01 and 30.

To return to the previous menu press the **Esc** key.

2. KEY LOCK

When set to ON, will deactivate all the front panel keys except the decimal point key. Press the decimal point key to unlock the keys.

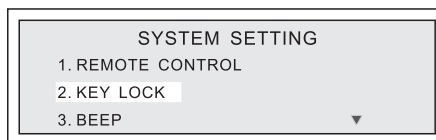

Press the **Enter** key to access the following sub menu:

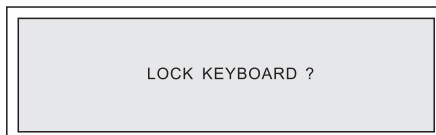

To lock the keyboard press the **Enter** key. The main page will be displayed and the 'Lock' symbol will be displayed at the bottom-right corner of the main menu. Press **Esc** key if you do not want to lock the front panel keys and then you can navigate up the menu structure as desired.

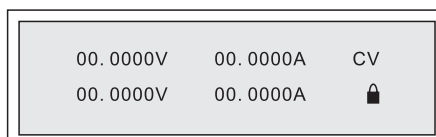

To unlock the front panel keys, press the decimal point key then the UNLOCK KEYBOARD menu will be displayed. Then press the **Enter** key to unlock it.

3. BEEP

With the BEEP setting, the user can select whether the buzzer sounds when a key is pressed.

Notes: 1. BEEP can be set to ON or OFF, default setting is ON.

2. When BEEP is set to ON, the buzzer will sound when pressing on any of the buttons or knobs.
3. When BEEP is set to OFF, pressing on any of the buttons or knobs will not cause the buzzer to sound.
4. When a system protection condition is detected, the buzzer will sound continuously to alert the user independent of the BEEP setting.

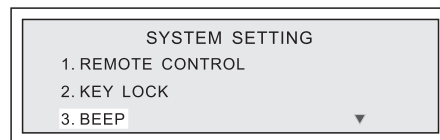

Highlight 3. BEEP item and press the  key to access the following menu:

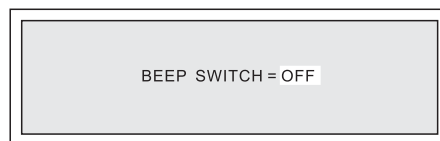

Press the  or  key to move the highlight to ON or OFF, and then, press the  key, to turn on or turn off the buzzer sound.

Press  key to enter the following page of the system setting menu:

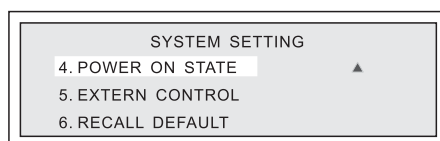

4. POWER ON STATE

This menu determines what state the power supply will enter into when it is turned on using the front panel switch or AC power is restored.

Highlight this menu item, and press the  key to enter the following sub-menu:

POWER ON STATE = OFF

- Note:
1. POWER ON STATE has three options of setting: LAST, USER and OFF, which can be highlighted by pressing the Δ ∇ keys.
 2. If it is set to LAST, the unit will record the output voltage and current settings and the power supply will remember these settings when it is turned back on.
 3. If it is set to USER, a user default setting list menu, which can be used to determine the power supply settings at AC turn on or AC power restoration, will be displayed as shown in the following figure.

USER SET
VOLT SET = 00.0000V
CURR SET = 00.0000A

4. Upon turn on after being switched off, the power supply will turn back on with its' default settings; output voltage is set to zero, and current limit is set to maximum unless Last or User is programmed.

Attention: The output is always in the OFF state when the AC power is restored or switched on, independent of the selected setting mode.

5. EXTERN CONTROL

This item is for setting the external control inputs as either external voltages (max. 0-5V) controlling the output voltage and / or current ("EXV" is displayed on the main page), or potentiometers (RES) controlling the output voltage and / or current ("EXR" is displayed on the main page).

Note: The EXTERN CONTROL mode will not function if master/slave mode is active.

SYSTEM SETTING
4. POWER ON STATE ▲
5. EXTERN CONTROL
6. RECALL DEFAULT ▼

With the above menu item highlighted press the \square (Enter) key, and to enter the following sub-menu:

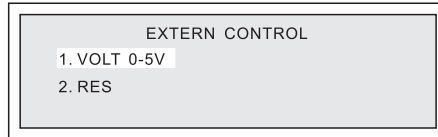

Then press the **Enter** key, and to enter the following sub-menu:

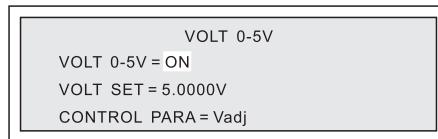

After selecting external voltage control item as ON, press the **Enter** key to move the cursor to the next line down. There you can set the control voltage range.

For example for the SP75VDC1500W if the voltage range is set to 3V, (Vset=3.0000V), the DC power output control is as shown in Figure (a). CONTROL PARA includes Vadj (output voltage setting), Iadj (output current setting) and Both (voltage setting and current setting).

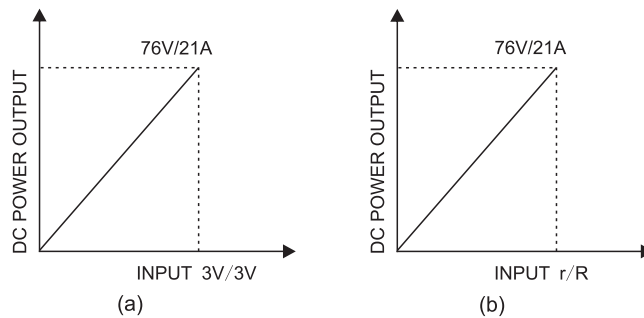

Similarly for the SP75VDC3000W, 0-3V can be used to program the current limit setting from zero to full scale.

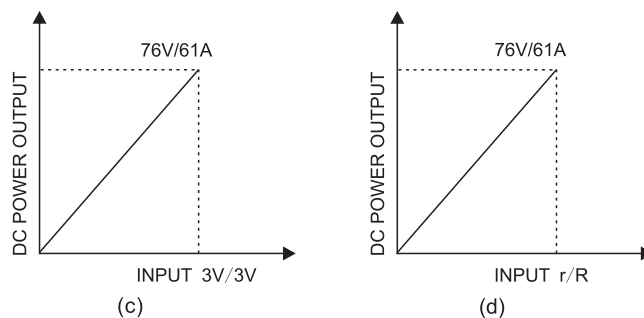

Selecting external potentiometer control is achieved in a similar manner to external voltage control, r is the divider resistance, R is the total resistance, the DC source setting simulation is shown in figure b/d.

6. RECALL DEFAULT

This menu is for restoring the system to the factory default settings.

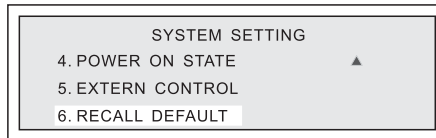

With the above menu item highlighted, press the **Enter** key to enter the following sub-menu:

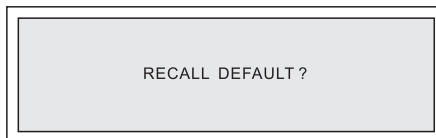

After pressing the **Enter** key again, all the parameter settings are restored to default value.

4.1.8 OUTPUT SETTING

With the top function menu displayed highlight OUTPUT SETTING and press **Enter** key to enter the OUTPUT SETTING sub menu. Pressing the **▲▼** keys, will successively show the following menu options.

1. VOLT LIMIT MAX; sets the MAX output voltage, the default is the Max voltage value;
2. VOLT LIMIT MIN; sets the MIN output voltage, the default setting is 0V;
3. CURR LIMIT MAX; sets the MAX output current, the default is the Max current value;
4. CURR LIMIT MIN; sets the MIN output current, the default is 0A;
5. ADVANCED FUNCTIONS, enables CURR SHARE function and SHORT MODE function.

OUTPUT SETTING Menu details:

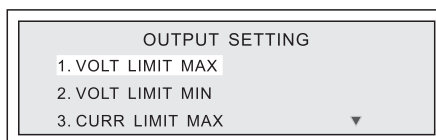

1. VOLT LIMIT MAX

When in the above menu, press the **Enter** key to enter the following sub-menu:

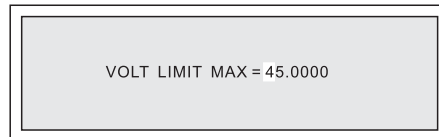

Use the front panel knob or number keys to modify the maximum output voltage limit.

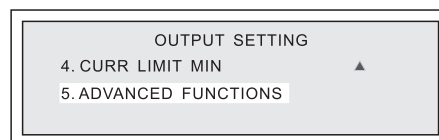

- 2. **VOLT LIMIT MIN** setting can be set in a similar fashion as 1 above.
- 3. **CURR LIMIT MAX** setting can be set in a similar fashion as 1 above.
- 4. **CURR LIMT MIN** setting can be set in a similar fashion as 1 above.

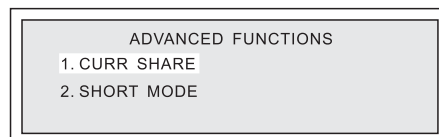

5. ADVANCED FUNCTIONS

With the above menu item highlighted, press the  key to enter the following sub-menu, including 1. CURR SHARE, current sharing function, and 2. SHORT MODE, enable the short protection when normal use, or disable the short protection when cable testing.



With the above menu item highlighted, press the  key to enter the following menu. Press the   keys to turn the average current sharing function ON or OFF, the default setting is "OFF".

Note: When CURR SHARE is on, the actual output voltage may be a little greater than setting value.

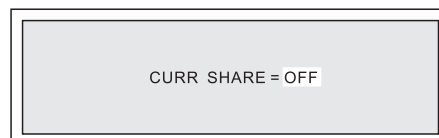

To activate the SHORT MODE, select the following sub menu and press the   keys to turn it ON or OFF, the default setting is "OFF".

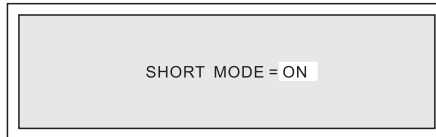

The default setting of SHORT MODE is on, which means when the power supply works in CC mode, output voltage is less than 0.7V, and output current is more than 2A, an output short circuit condition will be detected.

Using Δ ∇ to turn it to off, then the power supply can be used in the application like cable test, or circuit breaker test. The setting will be kept until the user change it voluntarily after power off.

4.1.9 INFORMATION

The first page of the INFORMATION menu, displays the power supply model number, kernel version number, and control software version.

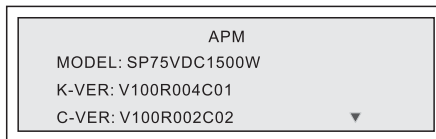

The second page displays display software version and serial number.

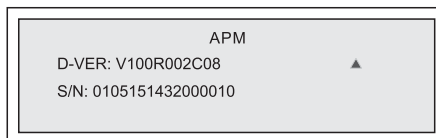



4.1.10 PROTECTION

Highlight PROTECTION and press the **Enter** key to select the PROTECTION menu, press the Δ ∇ keys to successively display the following sub-menu options.



1. OVP

With the above screen displayed, press the  key to select the Over Voltage Protection sub menu. And use the  keys to turn the OVP function ON. Press the  key to highlight the voltage value, and then set the over-voltage protection point using the knob or number keys. This feature protects the connected load by turning the output off should the output voltage exceeds the set point.

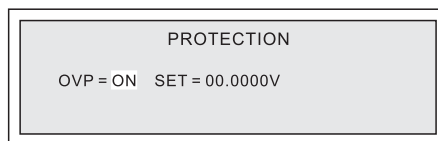

2. OCP



The Over-Current Protection setting can be adjusted in as manner similar to the OVP setting. If the output current exceeds the setting, the output will be turned off to protect the connected load.

3. OPP

The Over Power Protection setting can be adjusted in as manner similar to the OVP setting. If the output power exceeds this setting, the output will be turned off to protect the connected load.

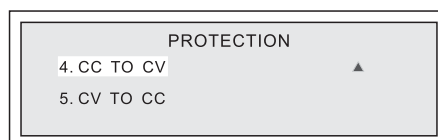
4. CC TO CV



While in the above menu, press the  key to enter the following sub-menu, press the  keys to turn on or off the CC TO CV protection. For description see section 4.1.10.4.

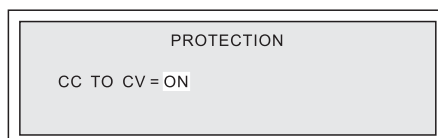

5. CV TO CC

Activate this protection mode in a manner similar to the CC TO CV.

4.1.10.1 Over Voltage Protection Function

If the DVM measured voltage is higher than the protection setting, the overvoltage protection function will be activated. The power supply will enter overvoltage protection mode (Over Voltage Protection), and the supply will automatically turn off the output voltage and current and the buzzer will sound. The OVP icon will be displayed. Press the **Enter** key to turn off the OVP protection and buzzer and remove the OVP icon.

00.0000V	00.0000A	CV
00.0000V	00.0000A	OVP

4.1.10.2 Over Current Protection Function

If the measured output current is higher than the protection setting, the overcurrent protection function will be activated. The power supply output will be automatically turned off and the buzzer will be sounded. The OCP icon will be displayed. Press the **Enter** key to turn off OCP and buzzer and remove the OCP icon.

00.0000V	00.0000A	CV
00.0000V	00.0000A	OCP

4.1.10.3 Over Power Protection Function

If the measured output power is higher than the protection setting, the Over Power Protection function will be activated. The power supply will automatically turn its' output OFF and the OPP icon will appear. Press the **Enter** key to turn the output back on, turn off the buzzer and remove the OPP icon.

00.0000V	00.0000A	CV
00.0000V	00.0000A	OPP

4.1.10.4 Constant Voltage Protection Function (CV TO CC)

When this function is activated, the power supply will stay in CV mode. If load changes force the system to transition from CV to CC (constant current) mode, the power supply will enter the "CV TO CC Protect" state that will shut off the output and display the CVC message on the display. Press **Enter** key to reset the protection and deactivate the buzzer.

4.1.10.5 Constant Current Protection Function (CC TO CV)

When this function is activated the power supply will stay in CC mode. If load changes forces the transition from CC to CV (constant voltage) mode, the power supply will enter the “CC TO CV Protect” state that will shut off output and display CCV message on the display. Press  key to reset the protection and deactivate buzzer.

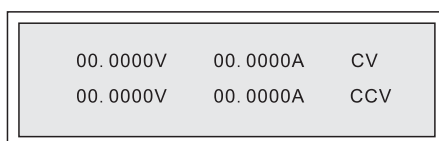

4.1.10.6 Over-temperature Protection Function (OTP)

If the temperature of the power supplies’ heatsinks exceeds protection limits, the power supply will enter the Over Temperature Protection mode. The output will automatically be turned off, the buzzer will sound, and then the following screen will be displayed. Press the  key to turn the output back on, turn off the buzzer and remove the OTP protection screen.

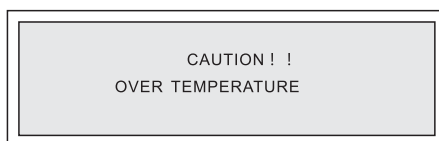

4.1.10.7 Short Circuit Protection

When the power supply works in CC mode, output voltage is less than 0.7V, an output short circuit condition is detected. The output will automatically be turned off, and the SCP screen below will be displayed. Press the  key to remove the protection screen and buzzer status.
Note: This protection is only detected when the output current is more than 2A.

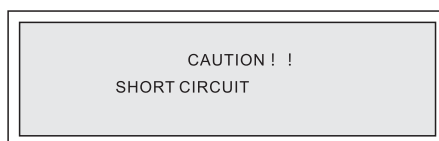

4.1.10.8 Over Voltage Protection

For each model, when its output voltage is higher than the setting point of hardware OVP shutdown point, the power supply will enter the “Over Voltage Protection” mode that will shut off the output and display the alarm message as shown in the following figure. Press the  key to remove the protection and buzzer status.

CAUTION ! !
OVER VOLTAGE

4.1.11 SERIES/PARALLEL

The power supplies use the Mater/Slave mode to increase the output power capability of a system while operating a single power source.

SERIES / PARALLEL
MASTER/SLAVE = MASTER
SELECT MODE = PAR

 **Warning!**

- Don't connect units in both series and parallel at the same time.
- Don't connect different models in parallel or in series.
- Assure that current share wires are not present when the outputs are connected in series.
- Make sure the wires and any fuses or breakers are of sufficient rated current and voltage and ensure the output is grounded at a single point when the power supplies are connected in series or parallel.

4.1.11.1 Series and Parallel Connection Setting

Figure (a) illustrates how to connect the communication cables between the units when they are connected in series. Figure (b) illustrates how to connect the communication cables between the units in when they are connected in parallel.

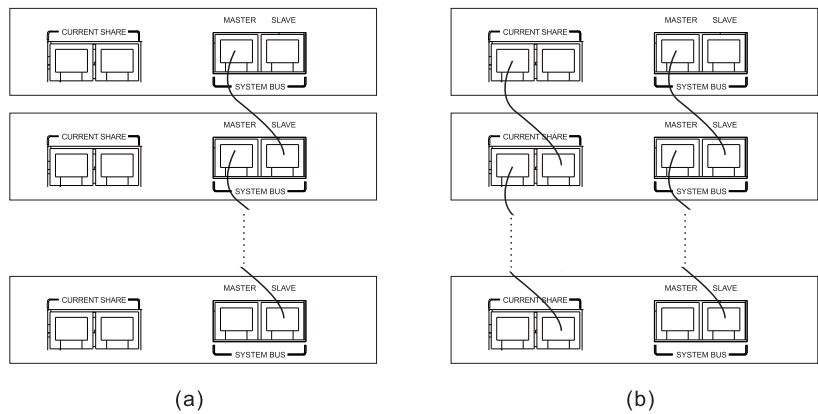

4.1.11.2 Series/Parallel Mode Setting

4.1.11.2.1 Setting of SLAVE



Caution!

- Set the SLAVEs first, and then the MASTER.
- Refer to Appendix A to get the most amount of slaves for different models, here we take 3 Slaves as an example.

After wiring is complete, configure one unit as the Master and the other three as Slave 1, 2 and 3. From the function menu highlight SERIES / PARALLEL and press the **Enter** key to enter the SERIES/PARALLEL sub menu. Press the **△▽** keys to select SLAVE 1 for the system and press the **Enter** key to confirm the setting. Use the same procedure to set SLAVE 2 and 3 for another two (2) supplies as shown below.

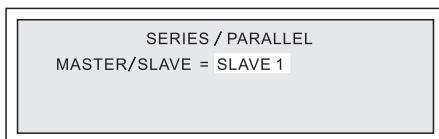



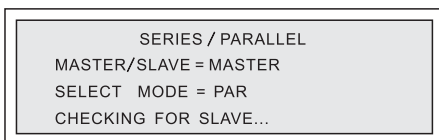

4.1.11.2.2 Setting of MASTER

From the function menu highlight SERIES/PARALLEL and press **Enter** key to enter the SERIES /PARALLEL sub menu. Press the **△▽** key to select MASTER for the supply and press the **Enter** key to confirm. The highlight will continue to the next line for the PAR/SER mode selection. Press the **△▽** keys to select PAR for the particular supply and press the **Enter** key to confirm the setting. After the unit is configured to be the Master, it will start searching for all slaves that are connected to the Master.

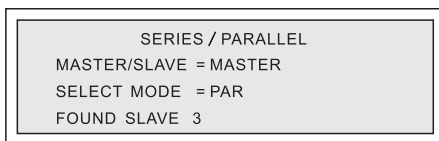

The master unit display will appear as below once the slaves are found as long as communications between the units is normal:



At the current interface, press the  key to the following interface. Press the   keys and  key to select and confirm to release from the Master-slave mode or keep that.

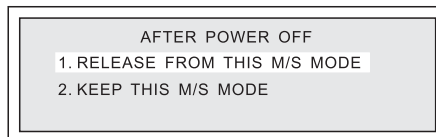

The MASTER unit will display the following when operating:

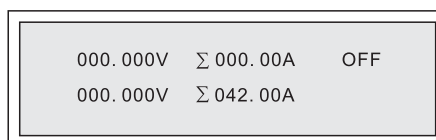

To release from this operation mode (parallel operation mode in this example), turn off of the output of Master unit, press the decimal point key to return to the local operation for the slaves. Or to access to the SELECT MODE item by using the front panel keys of the Master, select OFF option and press the  key to confirm.

The MASTER can have two functions as described below:

1. Once the Master and Slave settings are done, users can then operate the Master only to set up the combined output voltage and current of the complete system.
2. The MASTER unit accepts all the measured values from SLAVEs, and calculates all the statistics to show on its' main screen. In addition, if one of the SLAVE units triggers any of their set protection features, the protection information will be shown on the masters' main screen. Then the MASTER and all the SLAVEs will turn off, and the MASTER/SLAVE control will be deactivated.

 **Caution!**

- If multiple DC power supplies are connected in series or parallel, only one DC power supply can be set as MASTER and the rest are to be set as SLAVEs.
- If different SLAVEs are set to be the same number (such as SLAVE 1 & SLAVE 1), a communication error will occur. If this happens turn off the series / parallel control mode. Then set the SLAVE numbers to be unique, and resume series / parallel operation.
- After power-off, if you want to keep the previous Master-slave mode setting successfully, please turn on the Slave first, then turn on the Master.

4.1.11.2.3 List of Series and Parallel Errors

If abnormal communications occur, the MASTER searches for SLAVEs and will trigger the following screen to be displayed:

SERIES / PARALLEL MASTER/SLAVE = MASTER SELECT MODE = PAR ERR: FOUND NON SLAVE

If the “MASTER” reports an alarm during operation the units outputs will turn off, the buzzer will sound and the following screen will be displayed on its front panel:

000.000V	Σ 000.00A	OFF
050.000V	Σ 100.00A	OUT





This could be caused by the following problems:

1. There are more than one “SLAVE” with same name;
2. There is more than one power supply set as “MASTER”;
3. A communication failure has occurred between the “MASTER” and the “SLAVEs” during operation;
4. The “SLAVE” outputs are not synchronized;
5. A “SLAVE” unit shutdown is not synchronized;

4.1.12 TIMER CONTROL

From the main control screen please press  button, to select the TIMER CONTROL sub-menu.

TIMER CONTROL = OFF TIMER = 00: 00: 00

Press  or  to turn on or off timer control function. After selecting timer control item as ON, Press the  key to move the cursor to the next line down. There you can set the length of the time by the knob or number keys. The maximum time that can be set is 99 hours 59 minutes and 59 seconds. After setting up the time, please press the  key to return to the main page.

After setting up the voltage and current and press the **On/Off** key to turn on the output, the screen will show the countdown of the timer. Once it reaches down to zero, the supply will turn off the output automatically.

Note: TIMER CONTROL mode will not work when the units are in master/slave mode.

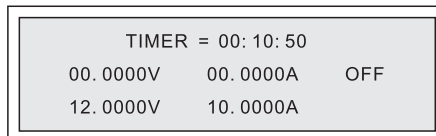

- The timing function is not repetitive. Once the time counts down to 0, the output is turned off and TIMER CONTROL is set to OFF.

4.1.13 SPECIAL TEST FUNCTIONS

1. PROGRAM MODE

The user can program executable LIST files that will define a wave shape of the output voltage and current that can be repetitive or non-repetitive as desired. Follow the instruction below to define the files, load and execute them.

From the top menu highlight SPECIAL TEST FUNC and press **Enter** to enter the sub-menu as below.

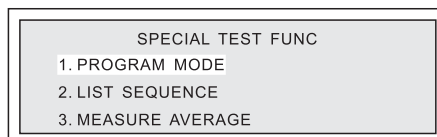

Then select PROGRAM MODE to display the following options:

1. EDIT FILE FORMAT
2. EDIT LIST FILE
3. LOAD LIST FILE

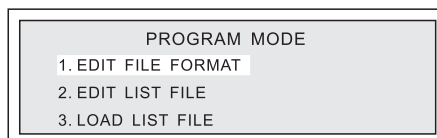





- (1) Select EDIT FILE FORMAT.
- (2) The screen displays the default “List” Modes as shown below.

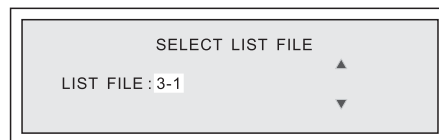



2*150 Steps	Set List1 of 2 variables and 150 steps
3*25 Steps	Set List2 of 3 variables and 25 steps
5*30 Steps	Set List3 of 5 variables and 30 steps

- (3) Select the desired list modes and press the  to confirm.
- (4) Press the  +  key to choose EDIT LIST FILE to confirm.
- (5) The display will show a file name as below, press   +  keys to choose a file name.

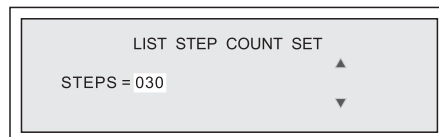

- (6) Press the , the display will show LIST STEP COUNT SET, press the   +  to confirm “LIST FILE 1” and Steps.



- (7) The display will show “LIST MODE SELECT”, press   button and select the operation mode amongst
 - a) LOOP which means LIST FILE loop execution.
 - b) CONT which means LIST FILE execution countdown, the execution will stop upon completion until the next touch of the  key.
 - c) STEP which means LIST FILE execution will stop at each step until the next touch of the  key.

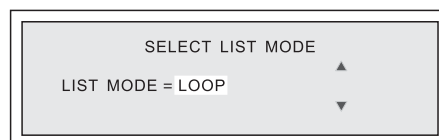

- (8) The display will show the content as below, press the **0**~**9**+**Enter** to set the output voltage start value (Vstar), output voltage end value (Vend), and rate of voltage change (Vrate).

Note: The Vrate can be set from 0.00001V/s to 4000V/s.

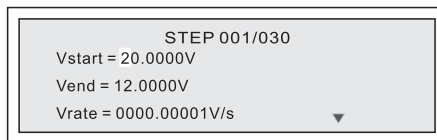

- (9) Press the **▽** button, to enter the next page, set the current limiting value (Iset) and time duration (Tcon), using a setting method similar to that in (8) above.

Note: The Tcon can be set from 0s to 99999.999s.

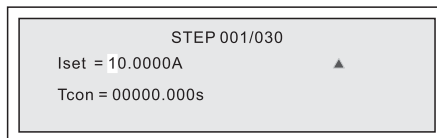

- (10) After completion of STEP1 settings, press the **Enter** button to enter STEP 2. Select the settings for STEP2 in a manner similar to STEP 1.

- (11) Continue to set up subsequent steps until you have programmed all the desired steps.

- (12) If desired to add additional program files repeat steps of 5~10 to edit other LIST FILES.

- (13) To load the file choose LOAD LIST FILE and confirm.

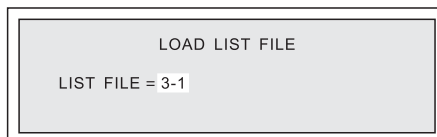

- (14) The power supply will display the RUN LIST menu as shown below.

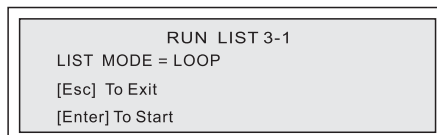

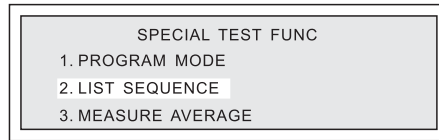

Press the **Enter** key to start execution of the programmed wave shape.

2. LIST SEQUENCE

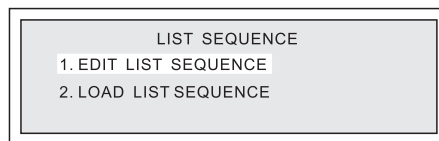

Highlight 1. EDIT LIST SEQUENCE item and press the  key to display the sub-menu below.



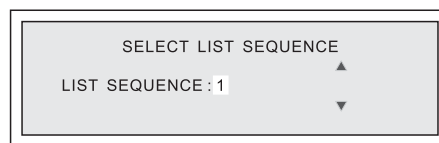

The display will show a file name as below, press  +  keys to choose a file name.

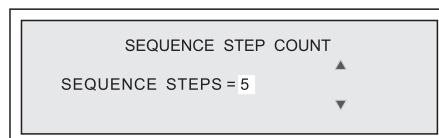

Press the  key, the display will show SEQUENCE STEP COUNT, press the  +  keys to confirm "LIST SEQUENCE 1" and Steps.



The display will show "SELECT SEQUENCE MODE", press  button and select the operation mode amongst

- a) CYCLE which means the waveform will output automatically during the cycle.
- b) STEP which means SEQUENCE execution will stop at each step until the next touch of the  key.

```
SELECT SEQUENCE MODE
SEQUENCE MODE = CYCLE  ▲
                       ▼
```

The display will show the content as below, after pressing the **Enter** key. Press the **0**~**9**+**Enter** to set the cycle times, which from 0 to 9999999, and 0 means endless loop.

```
SELECT SEQUENCE MODE
SEQUENCE MODE = CYCLE  ▲
CYCLE = 2000           ▼
```

Press the **▽** key to select the list files. Each step is a complete file saved in PROGRAM MODE menu. Press the **0**~**9**+**Enter** keys to set the run times of the current step.

```
SEQUENCE STEP
STEP = LIST 3-2        ▲
COUNT = 2000         ▼
```

Highlight 2. LOAD LIST SEQUENCE item and press the **Enter** key to select the sequence file.

```
LOAD LIST SEQUENCE
LIST SEQUENCE = 1
```

The display will show the content like below, press **Enter** key to run the sequence.

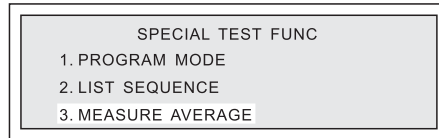

```
RUN SEQUENCE 1
SEQUENCE MODE = CYCLE
[ESC] To Exit
[Enter] To Start
```

3. MEASURE AVERAGE

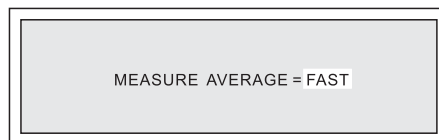

Highlight MEASURE AVERAGE and press the  key to display the setting sub-menu below.





The averaging times of the output voltage, current and power measurements can be adjusted to be FAST, MEDIUM or SLOW by using the   keys to display the desired speed and then pressing  key to select.

4.1.14 ADDITIONAL FUNCTIONS

1. QUICK SET

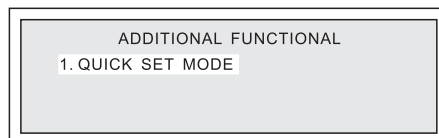
From the top menu highlight ADDITIONAL FUNCTIONAL and press the  key to display the ADDITIONAL FUNCTIONS menu.



Press the  to enter QUICK SET MODE menu. Pressing the  key again will display the voltage and current setting parameters which are stored in the units' memory.

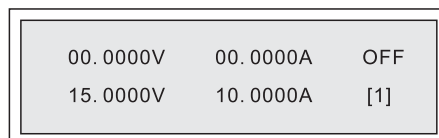

The user can change the parameters by pressing [0] ~ [9], the display will show the new settings, and the number at the right-bottom of the front panel will also be changed. Press the [Esc] key to exit quick set mode.

 **Note**

- Parameters should be preset and stored in memory.
- All the front keys are locked except [Esc] key and [On/Off] key when the power supply is in the quick set mode.

4.2 Rear Panel

Rear panel of 1U units.

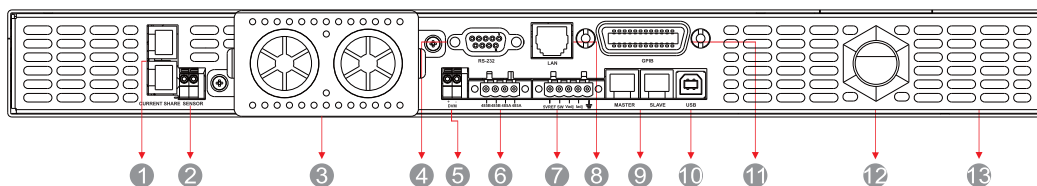

Rear panel of 2U units.

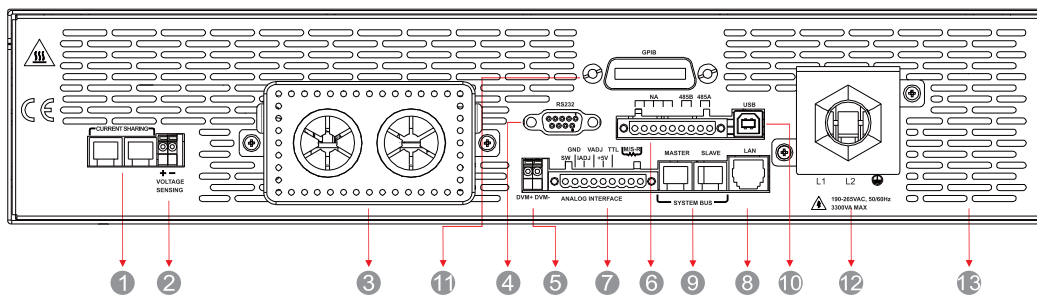

- ① Current sharing connectors, used for connecting between parallel units to enable current sharing.
- ② Remote sense wire connector, used for connecting wires to the remote sensing point for regulating the voltage at the load and compensating for wiring voltage drops.
- ③ DC output terminals.
- ④ RS-232 communications connector.
- ⑤ DVM connector.
- ⑥ RS485 communications connector.
- ⑦ ANALOG INTERFACE terminal which has GND, SW (for remote turn on input, when the input is more than 2.6 VDC, the unit will turn on, when the input is less than 1.2V, the unit will turn off), Iadj (for external analog voltage or potentiometer input to remotely control the output current regulating point of the power supply), Vadj (for external analog voltage or potentiometer input to remotely control the output voltage regulating point of the power supply) and 5V.
- ⑧ LAN communications connector.
- ⑨ SYSTEM BUS control; used for communication between the units for master and slave control.
- ⑩ USB communications connector.
- ⑪ GPIB communications connector.
- ⑫ AC Power input connector; pay attention that the ground terminal wire is connected to earth ground.
- ⑬ The fan duct outlets; do not block the fan duct outlets otherwise the units' cooling may be compromised.

4.2.1 Input Connection



Warning!

- Be sure to connect the green/yellow wire to connect ⊕ terminal of the AC Power input terminal block to earth ground, otherwise an electric shock hazard may exist!
- There is certain danger on connection of AC power supply, please assure that the AC power cable is installed by a qualified electrician or technologist. Also if the unit AC input is to be hardwired please assure that this is done by a qualified electrician.

- This supplied, safety approved, AC power supply cable is #10 AWG size (SJTW or STW or equivalent. min. 80°C) that can handle the highest rated input current. If the AC power cable is in need of replacement please assure the type and rating is approved by qualified engineer or electrician before installation to prevent possible fire or shock hazard.
- Be sure to disconnection from AC before access to DC output and AC input compartment.

 **Note**

- An external circuit breaker which disconnects all current carrying conductors for the AC input, detailed specifications as follow.
 - a) Circuit breaker must be suitably located and easily reached.
 - b) Circuit breaker must be marked as the disconnecting device for the equipment.
 - c) Circuit breaker must be CSA or UL certified in Canada and USA respectively and to the relevant local standard in other countries.

Power	600W		800W
Breaker	110/120VAC, 20A or 220/230/240VAC, 15A		110/120VAC, 25A or 220/230/240VAC, 15A
Power	1000W/1200W		1500W/1600W
Breaker	110/120VAC, 20A or 220/230/240VAC, 15A		110/120VAC, 25A or 220/230/240VAC, 15A
Power	2000W	3000W	4000W
Breaker	220/230/240VAC, 20A	220/230/240VAC, 25A	220/230/240VAC, 30A

Input Connections for 1U units:

1. Strip the outside insulation of the AC cable approximately 35 mm. Strip 10 mm of insulation from the end of each of the wires.
2. Use a Phillips number 2 screwdriver to loosen the 3 screws on the AC terminal cover plate, and remove the plate being sure to not lose the screws.
3. Loosen the plastic nut of the supplied cable strain relief clamp.
4. Pass the cable end including the line wire, neutral wire, and ground wire through the cable clamp and nut according to the direction of the drawing below, and then insert it into the line, neutral, and ground terminals respectively.
5. Using a suitably sized flat blade screwdriver tighten the screws on the top of terminal block assuring the wires are held tightly.
6. Replace and fasten the terminal cover plate, and tighten the plastic nut of the cable strain relief clamp.

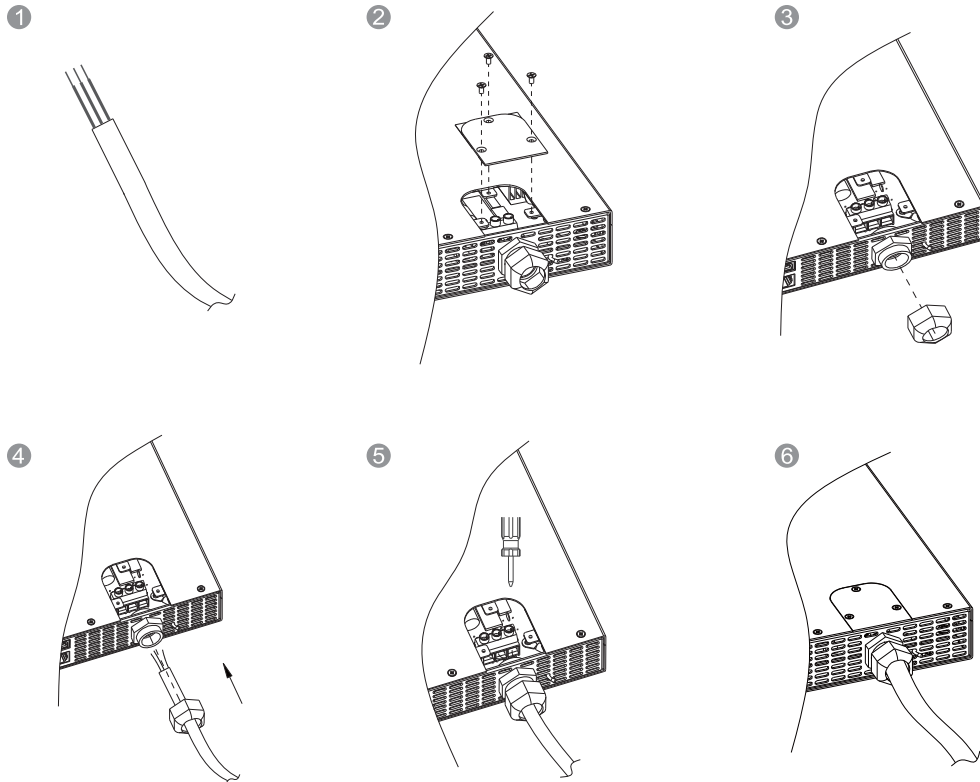

Input Connections for 2U units:

1. Strip the outside insulation of the AC cable approximately 25mm. Strip 7mm of insulation from the end of each of the wires.
2. Loosen the plastic nut of the supplied cable strain relief clamp.
3. Pass the cable end including the line wire, neutral wire, and ground wire through the cable clamp and nut according to the direction of the drawing below, and then insert it into the line, neutral, and ground terminals respectively.
4. Using a suitably sized flat blade screwdriver tighten the screws on the top of terminal block assuring the wires are held tightly.
5. Replace and fasten the terminal cover box, and tighten the plastic nut of the cable strain relief clamp.

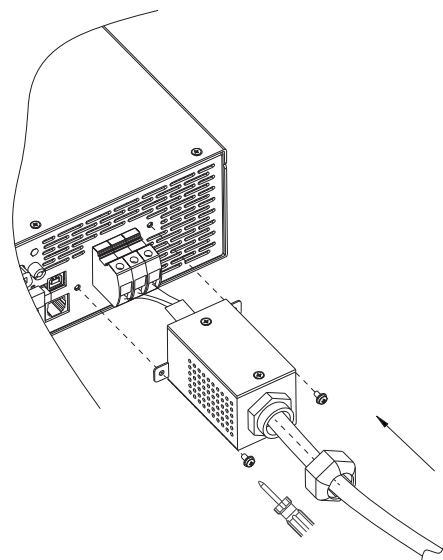

4.2.2 Load Connections



Warning!

- When connecting the load, turn off the power supply by turning off the AC power switch or disconnecting the AC power cable.
- Assure that all the screws are properly tightened.



Attention!

Consider the following issues when connecting the load.

- Assure that the wire used is rated to handle the maximum output current of the power supply in the maximum expected ambient temperature.
- Assure that the withstanding voltage rating of the insulation of the wires is greater than maximum output voltage of DC power supply or series connection voltage of the power supplies.
- The maximum wire length and voltage drop.
- Load noise and impedance effect.

Please refer to the table below to select cable size. Also consider temperature rating of the copper wires and voltage drop to the load:

Rated Current of equipment (A)	Minimum Conduct Sizes		Rated Current of equipment (A)	Minimum Conduct Sizes	
	Nominal Cross-sectional Area (mm ²)	AWG or kcmil		Nominal Cross-sectional Area (mm ²)	AWG or kcmil
13~16	1.5	14	125~160	50	0
16~25	2.5	12	160~190	70	000
25~32	4	10	190~230	95	0000
32~40	6	8	230~260	120	250 kcmil
40~63	10	6	260~300	150	300 kcmil
63~80	16	4	300~340	185	400 kcmil
80~100	25	2	340~400	240	500 kcmil
100~125	35	1	400~460	300	600 kcmil

Load connections for 1U units:

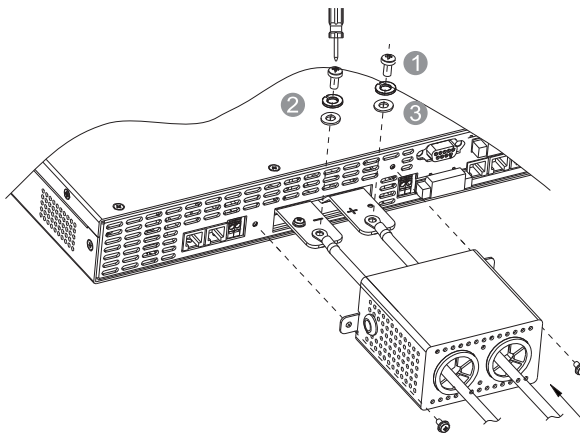

- ① M6*12 screws
- ② Spring washer
- ③ Washer

3. Install the safety outer cover to avoid contact with live terminals.

1. Strip 10 mm off the end of each of the wires, and install ring type crimp terminal using proper tooling.
2. Use a Phillips Number 3 screwdriver to secure the DC output positive and negative terminals to the termination bars. Assure that the screws are tight and that the connection is of correct polarity.

Load connections for 2U units.

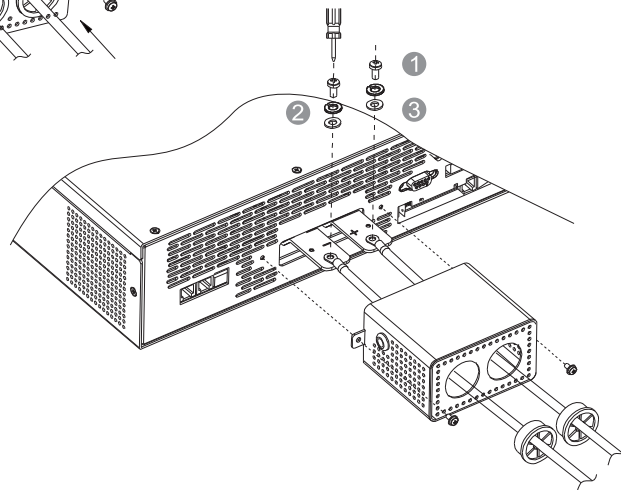

4.2.3 Remote Compensation

4.2.3.1 Connecting Method

1. Remote sensing allows the power supply to automatically compensate for the voltage drop in the load leads. The 1U and 2U units can be compensated at most 5V but using wires large enough to assure less than 1 volt total voltage drop is highly recommended.
2. The correct connection is shown on the chart. Use AWG 22 wire (best to use twisted pair wires or cable) and connect the 2 wires to the positive and negative load terminals and route the other ends to the Sensor+ and Sensor- inputs at the rear panel. Be sure to strip 5~7 mm of insulation off the wires before installing them into the sense line terminal block and assure that the wires are connected in the correct polarity.

4.2.3.2 Sensor Wire Not Connected or Reverse Polarity

The polarity of sensor wire must be connected in the correct polarity, that is “+” sense wire terminal connects with the “+” output terminal or “+” load terminal, while the “-” sense wire terminal connects with the “-” output terminal or load terminal. If the sense wire polarity is reversed, the power supply output will be tuned off.

The Power supply will operate properly even if the sense wires are not connected but the load regulation will not quite as accurate as the sensing point will be inside the power supply.

Note: Please follow the steps given below should the sense wire be connected in reverse:

1. First turn-off the unit;
2. Disconnect one end of the sense wires and connect to the correct polarity.
3. Turn the unit back on.

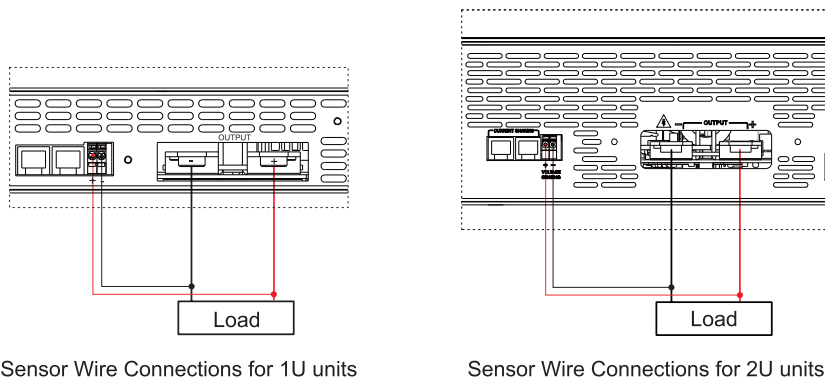

Note: Do not connect sensor wires to the load when units are connected in series.

4.2.4 DVM Function

DVM is digital voltage meter, make sure that DVM+/- inputs are connected to the right polarity of the measured load points. The connection wire should be 22 AWG, strip off 5~7 mm of insulation off the wire end.

5 Application

5.1 External Setting

The external setting is adjusted using the EXTERN CONTROL menu. The programmable DC supply can be controlled by external voltages (0~5V) or external potentiometers (5K~10K) in order to remotely adjust the power supply voltage and current regulation settings. See figures below for connecting the external control inputs.

Connection of Voltage or Potentiometer inputs.

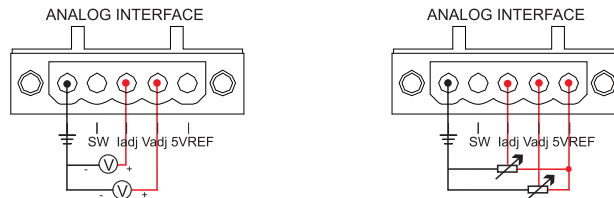

The external potentiometers or voltage sources will proportionately adjust the voltage and current regulation points of the power supply according to the programmed or default internal setting of these inputs.

00.0000V	00.0000A	OFF
12.0000V	10.0000A	EXV

5.2 Timer Control Function

The timer function is programmed using the TIMER CONTROL menu as described in section 4.1.12. Activate the timer by highlighting OFF and use the Δ ∇ keys to select ON. Press the **Enter** key on the front panel to start the timer which will turn on the power supplies output and count down toward zero. The power supplies' output will be turned off when the timer reaches zero.

TIMER = 00:10:50		
00.0000V	00.0000A	OFF
12.0000V	10.0000A	

5.3 SHORT MODE Function

The SHORT MODE function is useful for testing a breaker or cable. See below for the connection in testing mode.

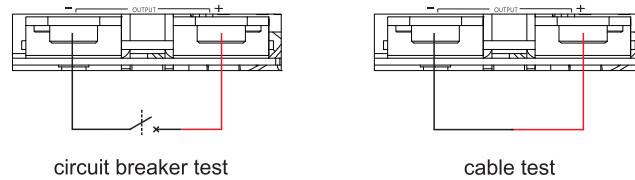

From the main display page press the **Menu** key to display the below function menu. Highlight the 2. OUTPUT SETTING item and press the **Enter** key to select.

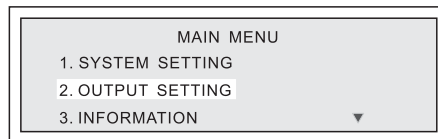

Highlight the 5. ADVANCED FUNC item and press the **Enter** key to select.

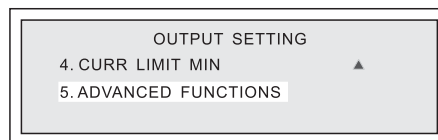

Highlight the 2. SHORT MODE item and press the **Enter** key to select.

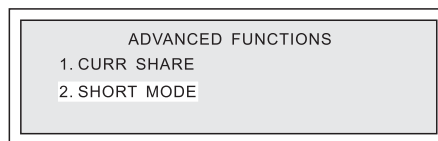

Use **▲▼ + Enter** key to turn it OFF, then the power supply can be used in the application like cable test, or circuit breaker test.

The setting will be saved after power off, until the user change it voluntarily.

CURR SHARE = OFF

5.4 Master-slave Mode Configuration

The schematic of cable connections below is for reference only. The user should install the cable connections based on actual application requirements.

Note: Take SP75VDC3000W as an example.

Parallel Connection

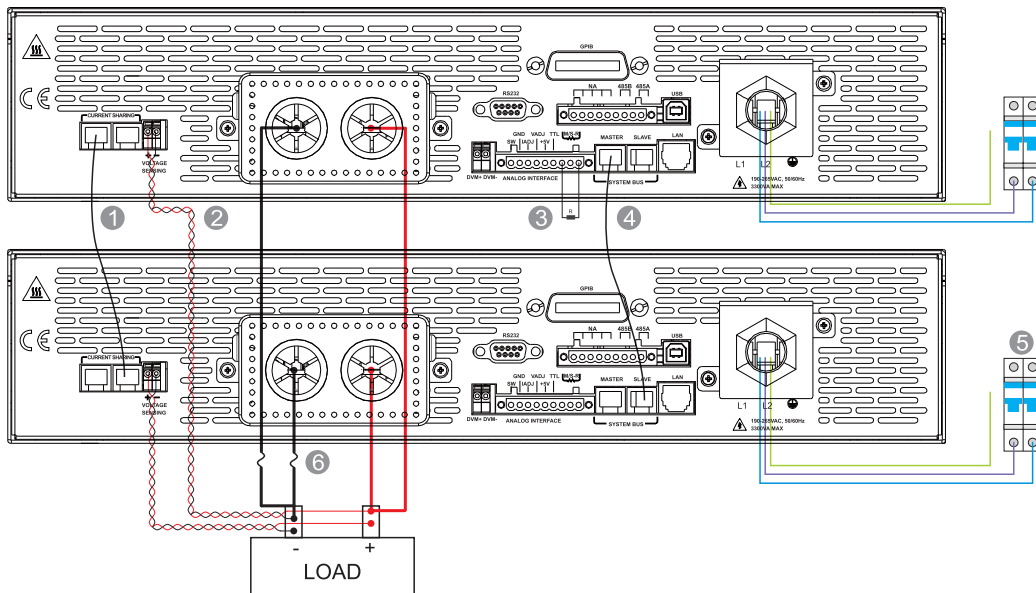

- ① Do not install the Master / Slave current sharing cable if the power supplies are connected in series, otherwise serious damage to the units may occur.
- ② The polarity of voltage sense wires must be correct.
- ③ 120Ω resistor terminator must be connected in the first unit or the last unit in Master/Slave mode.
- ④ SYSTEM BUS cable; connect for communication between master and slave units.
- ⑤ AC breaker, see 4.2.1 for details.
- ⑥ To ensure safety, include a fuse in series with each negative cable, the rated voltage and rated current of the fuse should be 1.5 times that of the power supply.

Series Connection

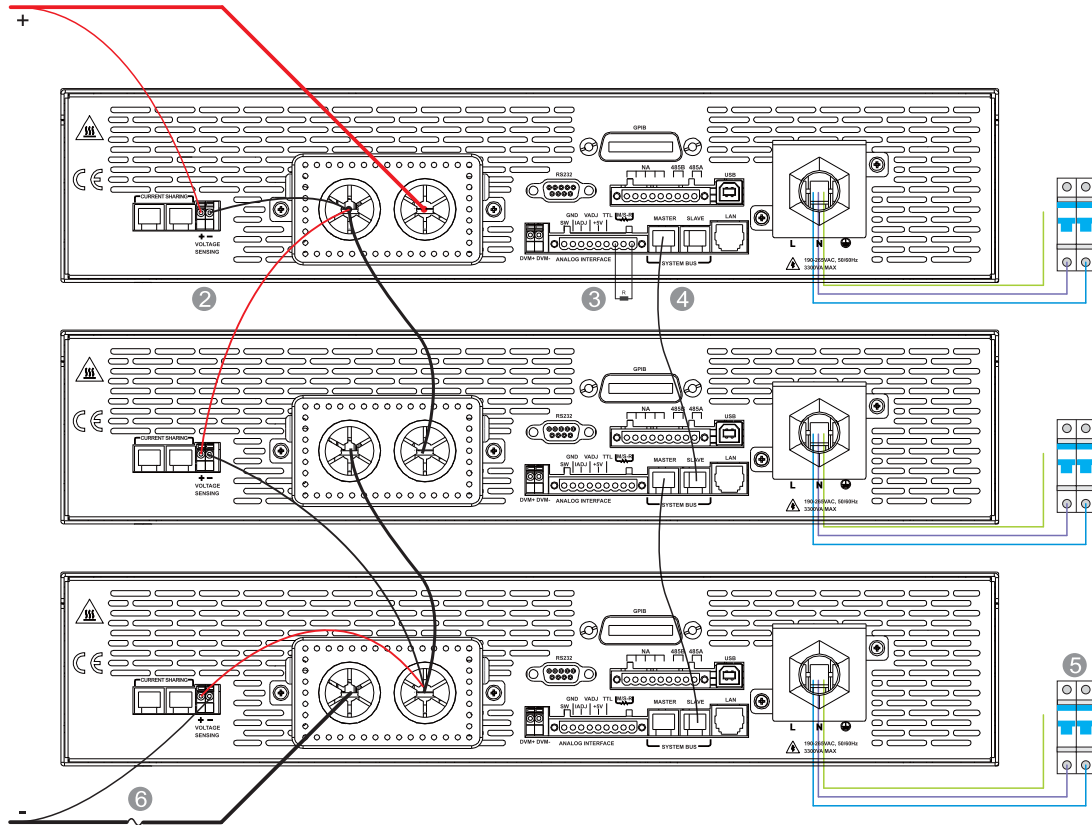

Assure that the power supplies inputs are initially turned off and connect the DC power cables. After confirmation of correct connection polarity turn on the input switch and, set the power supplies to the same voltage and current regulation points. Turn on the power supply outputs and confirm that the measured output voltages are within the rated tolerance range.

Set up the configuration of the master and slave units as described in section 4.1.11. Select the appropriate connection mode, series or parallel.

5.5 List Function

The list function can be used to program and execute a test program consisting of up to 30 steps. Each step consists of a start voltage (V_{start}), an end voltage (V_{end}), a rate of change of voltage (V_{rate}), a current limit setting (I_{start}) and a dwell time of the end voltage (T_{con}). The test program can be of 3 different trigger modes (Step/Continue/Loop). The test program waveform will look something like that shown below.

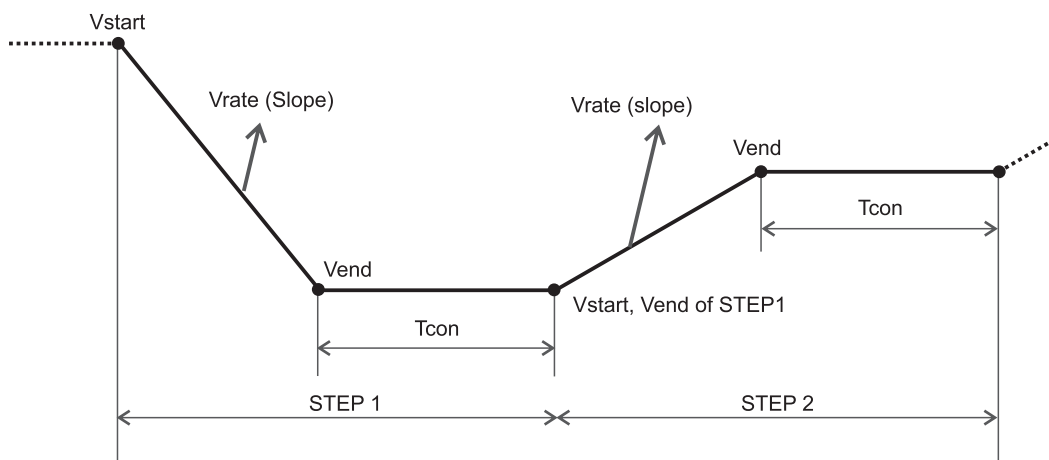

Program the test program using the procedure described in section 4.1.13 (1).

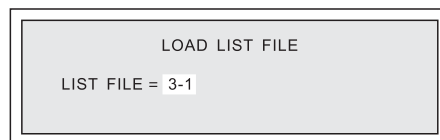

Load the List program file and run when desired.

Some models provides automotive power test waveforms compliant to DIN 40839 and ISO 16750-2 standards that can simulate common test conditions for electronic devices installed in automobiles.

SCPI Communication Protocol

SCPI is a programmable language standard designed especially for programmable instruments. It defines how to communicate with the instruments from an external computer. The APM programmable DC power supply uses SCPI programming language with two categories of commands: basic command (IEEE - 488.2 common command), and APM programmable DC power command. Press the Enter key before sending each commands.

6.1 SCPI Commands Descriptions

6.1.1 IEEE-488.2 Common Commands

This command includes all the common functions of IEEE-488.2 common command starting with *, regardless of hierarchy.

***IDN?**

This command will request download of information about the power source like manufacturer, model number, series number and software version number.

e.g. order syntax: ***IDN? <LF>**

return parameter: **APM** (manufacturer), **SP200VDC1500W** (model),
***** (series number), **V***R***C**** (software version number).

6.1.2 Command Specified by APM Programmable DC Power

6.1.2.1 System Commands

SYST:ETR

This command enables the remote control from extern control. 'REM' will appear at the bottom right corner of VFD screen.

SYST:LOC

This command enables the local operation from remote control.

SYST:RTE

This command enables the extern control from remote control.

SYST:REC:DEF

This command recalls factory default setting.

6.1.2.2 Setup Commands

VOLT <value>

CURR <value>

These commands set the voltage in volts and current in amperes.

OUTP <value>

This command enables or disable the specified output(s). The enable state is 1 (On), the disable state is 0 (Off).

6.1.2.3 Measurement Commands

MEAS:VOLT?

MEAS:CURR?

MEAS:DVM?

These queries perform a measurement and return the DC output voltage in volts, DC output current in amperes, or DVM in volts.

6.1.2.4 Other Commands

ASWRS?

This query returns the alarm code.

Alarm Code	Description	Alarm Code	Description
0	Normal	9	OVER VOLTAGE PROTECTION
1	OVP	A	SHORT CIRCUIT
2	OCP	B	FAN FAULT
3	OPP	C	OVER TEMPERATURE
4	CVC (CV TO CC)	D	NTC_FAIL
5	CCV (CC TO CV)	E	PRIMARY_FAIL
6	SLAVE OUT LINE	F	EEPROM DATA FAIL

ASWRC 0

This command clears the alarm signals.

OUTP?

This query returns the output state of the power supply.

VOLT?

CURR?

These queries return the DC setting voltage in volts or DC setting current in amperes.

SETT:VOLT:MAX <value>

SETT:VOLT:MIN <value>

SETT:CURR:MAX <value>

SETT:CURR:MIN <value>

These commands set the maximum or minimum of voltage in volts or current in amperes.

VOLT?MAX

CURR?MAX

VOLT?MIN

CURR?MIN

These queries return the maximum or minimum of voltage in volts or current in amperes.

PORT:OVP <value>

PORT:OCP <value>

PORT:OPP <value>

PORT:CCCV <value>

PORT:CVCC <value>

These commands enable or disable the protection functions. The enable state is 1 (On), the disable state is 0 (Off).

PORT:OVP:VOLT <value>

PORT:OCP:CURR <value>

PORT:OPP:POWR <value>

These commands set the protection value.

PORT:OVP:VOLT?

PORT:OCP:CURR?

PORT:OPP:POWR?

These queries return the protection value.

PORT:CURR:SHARE <value>

This command enables or disables the current sharing function.

The enable state is 1 (On), the disable state is 0 (Off).

PORT:ON:STATE <value>

This command sets the power on state of the DC power supply. 0 (OFF), 1 (LAST), 2 (USER).

PORT:ON:STATE?

This query returns the power on state of the DC power supply. 0 (OFF), 1 (LAST), 2 (USER).

SYS:USER:VOLT

SYS:USER:CURR

This command sets the voltage/current when the POWER ON STATE item set as USER.

SYS:USER:VOLT?

SYS:USER:CURR?

These queries return the voltage/current setting of the user-defined.

PTYPE <value>

This command sets the mode of the DC power supply.

0 (Master), 1 (Slave), 2 (Slave2), 3 (Slave3).

PMODE <value>

This command sets the connection mode of the DC power supply.

0 (Single mode), 1 (Parallel Connection), 2 (Series Connection).

SBEEP <value>

This command enables or disables the buzzer. The enable state is 1 (On), the disable state is 0 (Off).

POWER?

This query returns the output power of DC power supply in watts.

6.1.2.5 Command Format of RS485

If the user want to control a power supply by RS-485 communication interface, he must send the address information once first. And then the remaining command format is consistent with above-mentioned.

e.g. To set up 10 voltage for Address 5.

Command syntax **CADDR 5**, if returned parameter is **OK**, the power supply is ready.

Command syntax **VOLT 10**, the power is set for a voltage of 10V.

6.1.2.6 List Commands

LFILE <value>

This command sets the format of list file.

1 or 2 (2*150 steps), 3 or 4 (3*25 steps), 5 to 14 (5*30 steps).

LTOTA <value>

This command sets the total steps of the list file.

LMODE <value>

This command sets the running mode of the list file. 0 (CONT), 1 (STEP), 2 (LOOP).

LSTEP <value>

This command sets the step number under editing.

LVOLT <value>

This command sets the Vset.

LTCOM <value>

This command sets the Tcon. The value is from 00000.000 to 99999.999(s).

LSAVE

This command saves the list file.

LLOAD

This command loads the list file to the unit.

LRUNO

This command runs the list file.

For example

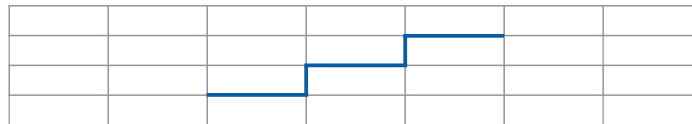

LFILE 1	Choose the list format 2*150 steps
LTOTA 3	Set List 1 to have 3 steps in total
LMODE 0	No repeat (repeat 1 time)
LSTEP 1	Choose step 1
LVOLT 5	Output voltage is set to 5 volts
LTCOM 1000	Output ON time is set to 1000s
LSTEP 2	Choose step 2
LVOLT 10	Output voltage is set to 10 volts
LTCOM 1000	Output ON time is set to 1000s
LSTEP 3	Choose step 3
LVOLT 15	Output voltage is set to 15 volts
LTCOM 1000	Output ON time is set to 1000s
LSAVE	Save List 1
LLOAD	Load List 1
LRUNO	Run List 1

LCURR <value>

This command sets the output current.

For example

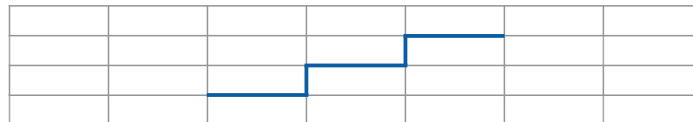

- LFIL 3 Choose the list format 3*25 steps
- LTOT 3 Set List 3 to have 3 steps in total
- LMO 0 No repeat (repeat 1 time)
- LST 1 Choose step 1
- LV 5 Output voltage is set to 5 volts
- LCUR 10 Output current is set to 10 ampere
- LTCOM 1000 Output ON time is set to 1000s
- LST 2 Choose step 2
- LV 10 Output voltage is set to 10 volts
- LCUR 10 Output current is set to 10 ampere
- LTCOM 1000 Output ON time is set to 1000s
- LST 3 Choose step 3
- LV 15 Output voltage is set to 15 volts
- LCUR 10 Output current is set to 10 ampere
- LTCOM 1000 Output ON time is set to 1000s
- LSAVE Save List 3
- LLOAD Load List 3
- LRUN Run List 3

LVSTR <value>

This command sets the start voltage.

LVEND <value>

This command sets the end voltage.

LVRAT <value>

This command sets the rate from start voltage to end voltage.

The value is from 0.00001 to 4000.00000(V/s).

LSTOP

This command exits the list.

For example



LFILE 5	Choose the list format 5*30 steps
LTOTA 2	Set List 5 to have 2 steps in total
LMODE 0	No repeat (repeat 1 time)
LSTEP 1	Choose step 1
LVSTR 5	Start output voltage is set to 5 volts
LVEND 10	End output voltage is set to 10 volts
LVRAT 2000	Voltage rate is set to 2000V/s
LCURR 10	Output current is set to 10 ampere
LTCOM 1000	Output ON time is set to 1000s
LSTEP 2	Choose step 2
LVSTR 10	Start output voltage is set to 10 volts
LVEND 15	End output voltage is set to 15 volts
LVRAT 2000	Voltage rate is set to 2000V/s
LCURR 10	Output current is set to 10 ampere
LTCOM 1000	Output ON time is set to 1000s
LSAVE	Save List 5
LLOAD	Load List 5
LRUNO	Run List 5

6.1.2.7 Sequence Commands

QFILE <value>

This command sets the sequence name, from 0 to 4.

QSTEP <value>

This command sets the total steps of the sequence.

QMODE <value>

This command sets the running mode of the sequence. 0 (CYCLE), 1 (STEP).

QCYCE <value>

This command sets the running times of the sequence.

QSTID <value>

This command chooses the step of the sequence to be edited, from 0 to 29.

QFNUM <value>

This command chooses the list file in the sequence.

QCONT <value>

This command sets the running times of the list file in the sequence.

QSAVE

This command saves all the settings of the sequence.

QLOAD

This command loads all the settings to the power supply.

QSRUN

This command runs the sequence.

QSTOP

This command exits the sequence.

QGOON

This command triggers the power supply to continue to output when the running mode set to STEP.

For example

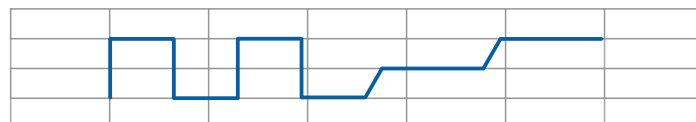

- | | |
|---------|---|
| QFILE 3 | Choose sequence 4 |
| QSTEP 2 | Set sequence 4 to have 2 steps in total |
| QMODE 0 | Repeat |
| QCYCE 3 | The sequence repeats 3 times |
| QSTID 0 | Choose step 1 |
| QFNUM 1 | Choose List 3-1 |
| QCONT 2 | List 3-1 repeats 2 times |
| QSTID 1 | Choose step 2 |
| QFNUM 2 | Choose List 3-2 |
| QCONT 1 | List 3-2 repeats 1 times |
| QSAVE | Save sequence 4 |
| QLOAD | Load sequence 4 |
| QSRUN | Run sequence 4 |

7 Introductions to Software

The DC Power Control Panel is monitoring software developed by APM Technologies especially for use with this series Programmable DC Power Supplies. The software features easy installation into a PC and convenient operation. Depending on the type of external power connection, the user can choose between SINGLE MODE, MULTI SETTING and MASTER/SLAVE MODE, which will switch the PC to corresponding screen after the software is started.

7.1 Software Installation

To ensure the normal operation of our monitoring software, your PC must have the following:

1. Pentium IV microprocessor or higher;
2. Windows XP Service Pack 2 operating system or higher.

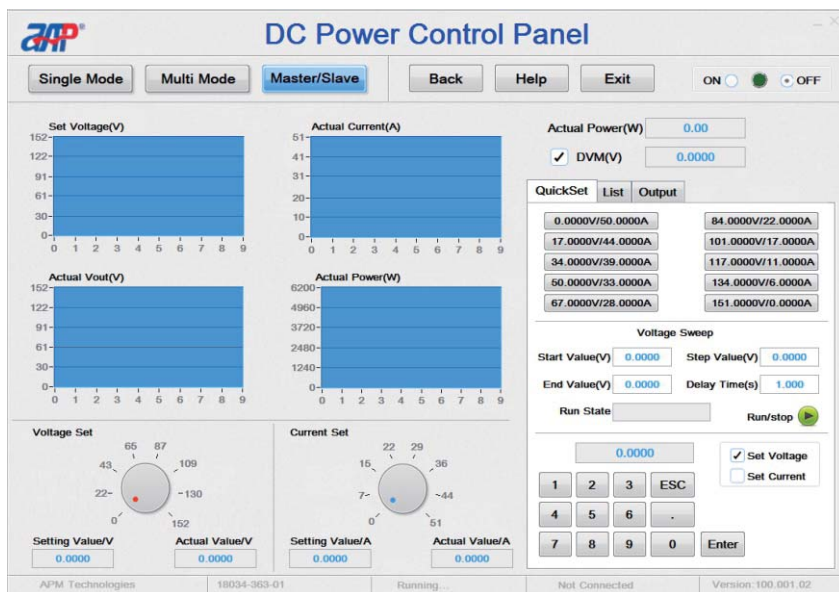

Please visit <http://en.apmtech.cn/Product-165.html> and download the monitoring software in "Data Download" field.

8 Troubleshooting

Problem	Causes	Solutions
Inaccurate measurement of V, I.	Drift of parts values lead to inaccuracies.	Units require regular calibration to allow accurate measurement.
Output is not within the scope of accuracy.	Drift of parts values lead to inaccuracies.	Units require regular calibration to allow accurate settings.
Over temperature protection (OTP) activates.	1. Ambient temperature is too high. 2. Ventilation holes are blocked.	1. Reduce ambient temperature. 2. Unblock vents, remove dust.
Over power protection (OPP) activates.	Output power is exceeds the setting.	Remove overload or adjust OPP setting.
Over current protection (OCP) activates.	Output current exceeds the specifications or OCP setting value.	Remove overload or adjust OCP setting.
Fan failure protection (FAN FAULT) activates.	Fan failure.	If you can't reset the protection status, ask your agent for help with fan replacement.
Software Version Conflict.	The Power supplies can not work in Master/Slave mode.	Ask your agent for help.
Over voltage protection (OVP) activates.	Output voltage exceeds the specifications or OVP setting value.	1. Adjust the OVP setting value. 2. If you can't reset the protection status, ask your agent for help.
Short Circuit protection activates.	Output wires are short-circuited or the loads connected to the power are short-circuited.	Turn off the output and check the cables to ensure they are properly connected before turning the power back on.
Power supply can not work (PRIMARY_FAIL)	Primary input voltage is over or under the required input voltage range.	Turn off the output and check the AC input to ensure the voltage is meet the requirement.
	Primary temperature is too high.	Turn off the output and check the ambient temperature is appropriate.
	PFC does not work or Bus current is over current.	Turn off the output, unpack the top cover and check the Bus voltage is 400VDC, you'd better ask your agent for help.

9 Installation

9.1 Product Dimensions

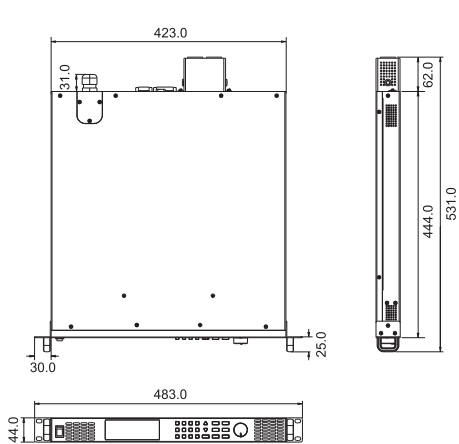

Outline Diagram of 1U units (mm)

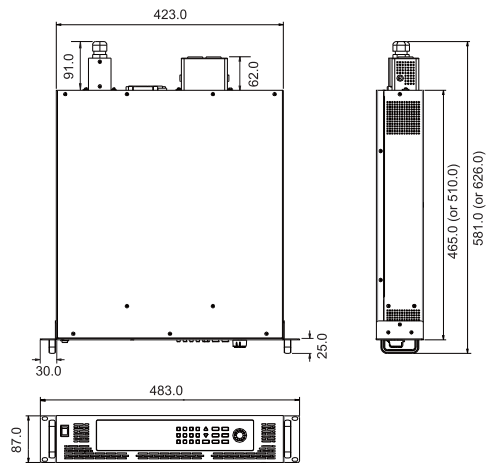

Outline Diagram of 2U units (mm)

Note: refer to appendix A to get the detailed information about the dimensions of power supplies.

9.2 Shelf Mounting Diagram of DC Power Supply

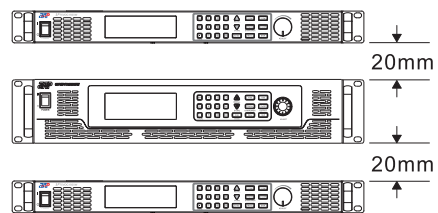
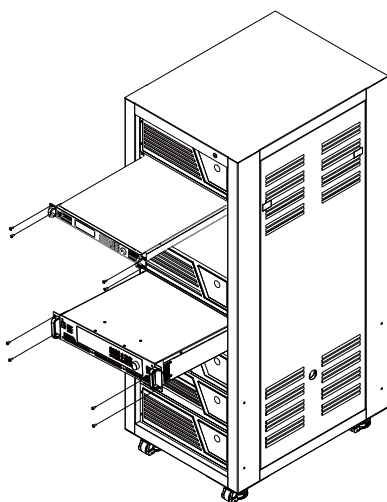

This series of programmable DC power can be installed in a standard 19-inch equipment rack, and it is easy to integrate into your test system.

To leave minimum clearance between power and power or power and other equipment for cooling as above.

9.3 Assemble Rack Mount Brackets

Rack mount brackets must be assembled before mounting the unit in a rack. Refer to the figure on the right to assemble the rack mount brackets.

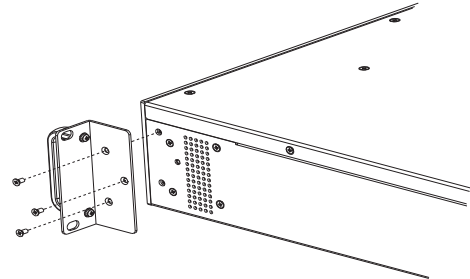

10 Recycling and Disposal

Do not discard this device and its accessories as solid waste. Please contact your local government agencies to find out how to properly recycle the product properly.

11 Contact Us

If you have any questions about the Programmable DC Power Supply, please contact us. We will be happy to answer any of your questions. Below are our contact details:

APM Technologies
 Add: # 7, Link Information Industry Park, Shuilianshan Road, Nancheng, Dongguan,
 Guangdong, China
 Land line: +86-769 22028588
 Fax: +86-769 22026771
 Website: www.apmtech.cn
 E-mail: mk@apmtech.cn

Appendix A Specifications

● 600W in 1U

Model	SP150VDC600W	SP200VDC600W	SP400VDC600W	SP600VDC600W	SP800VDC600W
Input Voltage	100~240VAC (90~265VAC range), Installation category II				
Input Frequency	50/60Hz (47~63Hz range)				
Power Factor	>0.98				
Input Power	750VA(MAX)	750VA(MAX)	750VA(MAX)	750VA(MAX)	750VA(MAX)
Output Voltage Range	0~150V	0~200V	0~400V	0~600V	0~800V
Output Current Range	0~10A	0~8A	0~7.5A	0~5A	0~4A
Output Power Range	0~600W	0~600W	0~600W	0~600W	0~600W
Voltage Load Regulation	15mV	15mV	30mV	30mV	40mV
Current Load Regulation	10mA	8mA	20mA	16mA	10mA
Voltage Display Resolution	1mV	1mV	1mV	1mV	1mV
Current Display Resolution	0.2mA	0.1mA	0.1mA	0.1mA	0.1mA
Voltage Programmable Resolution	3mV	3mV	8mV	12mV	16mV
Current Programmable Resolution	1mA	1mA	1mA	1mA	1mA
Voltage Setting Accuracy ^[1]	0.1%+15mV	0.1%+15mV	0.05%+100mV	0.05%+150mV	0.05%+200mV
Current Setting Accuracy	0.1%+10mA	0.1%+8mA	0.1%+20mA	0.1%+16mA	0.1%+10mA
Voltage Measurement Accuracy ^[1]	0.1%+15mV	0.1%+15mV	0.05%+100mV	0.05%+150mV	0.05%+200mV
Current Measurement Accuracy	0.1%+10mA	0.1%+8mA	0.1%+20mA	0.1%+16mA	0.1%+10mA
Voltage Ripple ^[2]	120mVp-p 40mVrms	120mVp-p 40mVrms	350mVp-p 40mVrms	350mVp-p 40mVrms	500mVp-p 60mVrms
Current Ripple ^[3]	40mA (Full Range) 10mA (TYP Value)	40mA (Full Range) 10mA (TYP Value)	25mA (Full Range) 10mA (TYP Value)	25mA (Full Range) 10mA (TYP Value)	25mA (Full Range) 10mA (TYP Value)
Line Regulation (Voltage)	0.02%+8mV	0.02%+8mV	0.02%+20mV	0.02%+30mV	0.02%+40mV
Line Regulation (Current)	10mA	10mA	10mA	8mA	10mA
Voltage Temperature Coefficient ^[4]	100ppm/°C	100ppm/°C	100ppm/°C	100ppm/°C	100ppm/°C
Current Temperature Coefficient ^[4]	150ppm/°C	150ppm/°C	150ppm/°C	150ppm/°C	150ppm/°C
DVM Resolution	1mV	1mV	8mV	12mV	16mV
DVM Precision ^[1]	0.1%+15mV	0.1%+15mV	0.05%+100mV	0.05%+150mV	0.05%+200mV
Operating Mode	Constant voltage (CV) / Constant current (CC)				

Model	SP150VDC600W	SP200VDC600W	SP400VDC600W	SP600VDC600W	SP800VDC600W
Remote Compensation	4V MAX	4V MAX	4V MAX	4V MAX	4V MAX
Master-slave Control	Yes	Yes	Yes	Yes	Yes
Response (Voltage Increase)	≤25ms	≤30ms	≤60ms	≤60ms	≤60ms
Response (Voltage Drop)	≤400ms (no load) ≤32ms (full load)	≤600ms (no load) ≤50ms (full load)	≤800ms (no load) ≤100ms (full load)	≤1200ms (no load) ≤100ms (full load)	≤1200ms (no load) ≤100ms (full load)
Load Transient Recovery Time ^[5]	≤2ms	≤3ms	≤3ms	≤3ms	≤3ms
Command Response Time	50ms				
Series Capability ^[6]	Up to 8 units	Up to 6 units	Up to 3 units	Up to 2 units	Not Recommended
Parallel Capability	Up to 10 units	Up to 10 units	Up to 10 units	Up to 10 units	Up to 10 units
Current Sharing ^[7]	40V	50V	120V	200V	250V
Efficiency (full load)	88%	87%	88%	88%	88%
Protection Function	OVP/OCP/OTP/OPP/SCP				
Input Fuse	10A, 125VAC/250VAC, fast-acting type				
Net Weight	9.3kg	9.3kg	9.5kg	9.5kg	9.5kg
Accessories Weight	1.0kg	1.0kg	1.0kg	1.0kg	1.0kg
Dimensions(WxHxD)	483.0x44.0x531.0 mm				
Communication Modes	1. RS232/RS485/USB/LAN; 2. RS232/RS485/USB/LAN/GPIB				
Operating Environment	Temperature 0~40°C, Relative Humidity 10%~90%(no condensation); Pollution degree 2, Installation category II, Indoor use.				
Cooling Mode	Forced air-cooling				
Altitude	2000m				

[1] %output+offset, when output voltage less than 5V, offset voltage is 30mV.

[2] Vp-p@20MHz, Vrms@1.25MHz.

[3] Arms@1.25MHz, the TYP Value is measured at the rated output voltage with 100% resistive load, and the measured value at full range of output voltage with 100% resistive load is less than the Full Range value.

[4] 0~40°C.

[5] Time for output voltage to recover within 0.5% of its rated output for a load change from 10% to 90% of its rated output current. Voltage set point from 10% to 90% of rated output.

[6] The communication must insulated users from output when using remote control and the output voltage exceeds 800VDC.

[7] Current Share error $I_e < (I_{av} * 2.5\% + 1) A$, $I_{av} = I_{sum} / n$, where I_{av} is average current, I_{sum} is total current and n is number of parallel units.

Note: Output voltage must be higher than 30% of maximum output voltage when Current Share function properly.

All specifications are subject to change without notice. Please visit our website for the most up to date specifications.

● **1000W in 1U**

Model	SP150VDC1000W	SP200VDC1000W	SP400VDC1000W	SP600VDC1000W	SP800VDC1000W
Input Voltage	100~240VAC (90~265VAC range), Installation category II				
Input Frequency	50/60Hz (47~63Hz range)				
Power Factor	>0.98				
Input Power	1300VA(MAX)	1300VA(MAX)	1300VA(MAX)	1300VA(MAX)	1300VA(MAX)
Output Voltage Range	0~150V	0~200V	0~400V	0~600V	0~800V
Output Current Range	0~10A	0~8A	0~7.5A	0~5A	0~4A
Output Power Range	0~1000W	0~1000W	0~1000W	0~1000W	0~1000W
Voltage Load Regulation	15mV	15mV	30mV	30mV	40mV
Current Load Regulation	10mA	8mA	20mA	16mA	10mA
Voltage Display Resolution	1mV	1mV	1mV	1mV	1mV
Current Display Resolution	0.2mA	0.1mA	0.1mA	0.1mA	0.1mA
Voltage Programmable Resolution	3mV	3mV	6mV	12mV	16mV
Current Programmable Resolution	1mA	1mA	1mA	1mA	1mA
Voltage Setting Accuracy ^[1]	0.1%+15mV	0.1%+15mV	0.05%+100mV	0.05%+150mV	0.05%+200mV
Current Setting Accuracy	0.1%+10mA	0.1%+8mA	0.1%+20mA	0.1%+16mA	0.1%+10mA
Voltage Measurement Accuracy ^[1]	0.1%+15mV	0.1%+15mV	0.05%+100mV	0.05%+150mV	0.05%+200mV
Current Measurement Accuracy	0.1%+10mA	0.1%+8mA	0.1%+20mA	0.1%+16mA	0.1%+10mA
Voltage Ripple ^[2]	120mVp-p 40mVrms	120mVp-p 40mVrms	350mVp-p 40mVrms	350mVp-p 40mVrms	500mVp-p 60mVrms
Current Ripple ^[3]	40mA (Full Range) 10mA (TYP Value)	40mA (Full Range) 10mA (TYP Value)	25mA (Full Range) 10mA (TYP Value)	25mA (Full Range) 10mA (TYP Value)	25mA (Full Range) 10mA (TYP Value)
Line Regulation (Voltage)	0.02%+8mV	0.02%+8mV	0.02%+20mV	0.02%+30mV	0.02%+40mV
Line Regulation (Current)	10mA	30mA	10mA	8mA	10mA
Voltage Temperature Coefficient ^[4]	100ppm/°C	100ppm/°C	100ppm/°C	100ppm/°C	100ppm/°C
Current Temperature Coefficient ^[4]	150ppm/°C	150ppm/°C	150ppm/°C	150ppm/°C	150ppm/°C
DVM Resolution	1mV	1mV	8mV	12mV	16mV
DVM Precision ^[1]	0.1%+15mV	0.1%+15mV	0.05%+100mV	0.05%+150mV	0.05%+200mV
Operating Mode	Constant voltage (CV) / Constant current (CC)				
Remote Compensation	4V MAX	4V MAX	4V MAX	4V MAX	4V MAX
Master-slave Control	Yes	Yes	Yes	Yes	Yes

Model	SP150VDC1000W	SP200VDC1000W	SP400VDC1000W	SP600VDC1000W	SP800VDC1000W
Response (Voltage Increase)	≤25ms	≤30ms	≤60ms	≤60ms	≤60ms
Response (Voltage Drop)	≤400ms (no load) ≤25ms (full load)	≤600ms (no load) ≤30ms (full load)	≤800ms (no load) ≤80ms (full load)	≤1200ms (no load) ≤80ms (full load)	≤1200ms (no load) ≤80ms (full load)
Load Transient Recovery Time ^[5]	≤2ms	≤3ms	≤3ms	≤3ms	≤3ms
Command Response Time	50ms				
Series Capability ^[6]	Up to 8 units	Up to 6 units	Up to 3 units	Up to 2 units	Not Recommended
Parallel Capability	Up to 10 units	Up to 10 units	Up to 10 units	Up to 10 units	Up to 10 units
Current Sharing ^[7]	40V	50V	120V	200V	250V
Efficiency (full load)	89%	87%	90%	90%	90%
Protection Function	OVP/OCP/OTP/OPP/SCP				
Input Fuse	30A, 125VAC/250VAC, fast-acting type				
Net Weight	9.3kg	9.3kg	9.5kg	9.5kg	9.5kg
Accessories Weight	1.0kg	1.0kg	1.0kg	1.0kg	1.0kg
Dimensions(WxHxD)	483.0x44.0x531.0 mm				
Communication Modes	1. RS232/RS485/USB/LAN; 2. RS232/RS485/USB/LAN/GPIB				
Operating Environment	Temperature 0~40°C. Relative Humidity 10%~90%(no condensation); Pollution degree 2, Installation category II, Indoor use.				
Cooling Mode	Forced air-cooling				
Altitude	2000m				

[1] %output+offset, when output voltage less than 5V, offset voltage is 30mV.

[2] Vp-p@20MHz, Vrms@1.25MHz.

[3] Arms@1.25MHz, the TYP Value is measured at the rated output voltage with 100% resistive load, and the measured value at full range of output voltage with 100% resistive load is less than the Full Range value.

[4] 0~40°C.

[5] Time for output voltage to recover within 0.5% of its rated output for a load change from 10% to 90% of its rated output current. Voltage set point from 10% to 90% of rated output.

[6] The communication must insulated users from output when using remote control and the output voltage exceeds 800VDC.

[7] Current Share error $I_e < (I_{av} * 2.5\% + 1) A$, $I_{av} = I_{sum} / n$, where I_{av} is average current, I_{sum} is total current and n is number of parallel units.
Note: Output voltage must be higher than 30% of maximum output voltage when Current Share function properly.

All specifications are subject to change without notice. Please visit our website for the most up to date specifications.

● **1200W in 1U**

Model	SP150VDC1200W	SP200VDC1200W	SP400VDC1200W	SP600VDC1200W	SP800VDC1200W
Input Voltage	100~240VAC (90~265VAC range), Installation category II				
Input Frequency	50/60Hz (47~63Hz range)				
Power Factor	>0.98				
Input Power	1500VA(MAX)	1500VA(MAX)	1500VA(MAX)	1500VA(MAX)	1500VA(MAX)
Output Voltage Range	0~150V	0~200V	0~400V	0~600V	0~800V
Output Current Range	0~10A	0~8A	0~7.5A	0~5A	0~4A
Output Power Range	0~1200W	0~1200W	0~1200W	0~1200W	0~1200W
Voltage Load Regulation	15mV	15mV	30mV	30mV	40mV
Current Load Regulation	10mA	8mA	20mA	16mA	10mA
Voltage Display Resolution	1mV	1mV	1mV	1mV	1mV
Current Display Resolution	0.2mA	0.1mA	0.1mA	0.1mA	0.1mA
Voltage Programmable Resolution	3mV	3mV	6mV	12mV	16mV
Current Programmable Resolution	1mA	1mA	1mA	1mA	1mA
Voltage Setting Accuracy ^[1]	0.1%+15mV	0.1%+15mV	0.05%+100mV	0.05%+150mV	0.05%+200mV
Current Setting Accuracy	0.1%+10mA	0.1%+8mA	0.1%+20mA	0.1%+16mA	0.1%+10mA
Voltage Measurement Accuracy ^[1]	0.1%+15mV	0.1%+15mV	0.05%+100mV	0.05%+150mV	0.05%+200mV
Current Measurement Accuracy	0.1%+10mA	0.1%+8mA	0.1%+20mA	0.1%+16mA	0.1%+10mA
Voltage Ripple ^[2]	120mVp-p 40mVrms	120mVp-p 40mVrms	350mVp-p 40mVrms	350mVp-p 40mVrms	500mVp-p 60mVrms
Current Ripple ^[3]	40mA (Full Range) 10mA (TYP Value)	40mA (Full Range) 10mA (TYP Value)	25mA (Full Range) 10mA (TYP Value)	25mA (Full Range) 10mA (TYP Value)	25mA (Full Range) 10mA (TYP Value)
Line Regulation (Voltage)	0.02%+8mV	0.02%+8mV	0.02%+20mV	0.02%+30mV	0.02%+40mV
Line Regulation (Current)	10mA	30mA	10mA	8mA	10mA
Voltage Temperature Coefficient ^[4]	100ppm/°C	100ppm/°C	100ppm/°C	100ppm/°C	100ppm/°C
Current Temperature Coefficient ^[4]	150ppm/°C	150ppm/°C	150ppm/°C	150ppm/°C	150ppm/°C
DVM Resolution	1mV	1mV	8mV	12mV	16mV
DVM Precision ^[1]	0.1%+15mV	0.1%+15mV	0.05%+100mV	0.05%+150mV	0.05%+200mV
Operating Mode	Constant voltage (CV) / Constant current (CC)				
Remote Compensation	4V MAX	4V MAX	4V MAX	4V MAX	4V MAX
Master-slave Control	Yes	Yes	Yes	Yes	Yes

Model	SP150VDC1200W	SP200VDC1200W	SP400VDC1200W	SP600VDC1200W	SP800VDC1200W
Response (Voltage Increase)	≤25ms	≤30ms	≤60ms	≤60ms	≤60ms
Response (Voltage Drop)	≤400ms (no load) ≤21ms (full load)	≤600ms (no load) ≤36ms (full load)	≤800ms (no load) ≤72ms (full load)	≤1200ms (no load) ≤72ms (full load)	≤1200ms (no load) ≤72ms (full load)
Load Transient Recovery Time ^[5]	≤2ms	≤3ms	≤3ms	≤3ms	≤3ms
Command Response Time	50ms				
Series Capability ^[6]	Up to 8 units	Up to 6 units	Up to 3 units	Up to 2 units	Not Recommended
Parallel Capability	Up to 10 units	Up to 10 units	Up to 10 units	Up to 10 units	Up to 10 units
Current Sharing ^[7]	40V	50V	120V	200V	250V
Efficiency (full load)	89%	90%	90%	90%	90%
Protection Function	OVP/OCP/OTP/OPP/SCP				
Input Fuse	30A, 125VAC/250VAC, fast-acting type				
Net Weight	9.3kg	9.3kg	9.5kg	9.5kg	9.5kg
Accessories Weight	1.0kg	1.0kg	1.0kg	1.0kg	1.0kg
Dimensions(WxHxD)	483.0x44.0x531.0 mm				
Communication Modes	1. RS232/RS485/USB/LAN; 2. RS232/RS485/USB/LAN/GPIB				
Operating Environment	Temperature 0~40°C. Relative Humidity 10%~90%(no condensation); Pollution degree 2, Installation category II, Indoor use.				
Cooling Mode	Forced air-cooling				
Altitude	2000m				

[1] %output+offset, when output voltage less than 5V, offset voltage is 30mV.

[2] Vp-p@20MHz, Vrms@1.25MHz.

[3] Arms@1.25MHz, the TYP Value is measured at the rated output voltage with 100% resistive load, and the measured value at full range of output voltage with 100% resistive load is less than the Full Range value.

[4] 0~40°C.

[5] Time for output voltage to recover within 0.5% of its rated output for a load change from 10% to 90% of its rated output current. Voltage set point from 10% to 90% of rated output.

[6] The communication must insulated users from output when using remote control and the output voltage exceeds 800VDC.

[7] Current Share error $I_e < (I_{av} * 2.5\% + 1) A$, $I_{av} = I_{sum} / n$, where I_{av} is average current, I_{sum} is total current and n is number of parallel units.
Note: Output voltage must be higher than 30% of maximum output voltage when Current Share function properly.

All specifications are subject to change without notice. Please visit our website for the most up to date specifications.

● **1500W in 1U**

Model	SP150VDC1500W	SP200VDC1500W	SP400VDC1500W	SP600VDC1500W	SP800VDC1500W
Input Voltage	100~240VAC (90~265VAC range), Installation category II				
Input Frequency	50/60Hz (47~63Hz range)				
Power Factor	>0.98				
Input Power	1900VA(MAX)	1900VA(MAX)	1900VA(MAX)	1900VA(MAX)	1900VA(MAX)
Output Voltage Range	0~150V	0~200V	0~400V	0~600V	0~800V
Output Current Range	0~10A	0~8A	0~7.5A	0~5A	0~4A
Output Power Range	0~1500W	0~1500W	0~1500W	0~1500W	0~1500W
Voltage Load Regulation	15mV	15mV	30mV	30mV	40mV
Current Load Regulation	10mA	8mA	15mA	10mA	8mA
Voltage Display Resolution	1mV	1mV	1mV	1mV	1mV
Current Display Resolution	0.2mA	0.1mA	0.1mA	0.1mA	0.1mA
Voltage Programmable Resolution	3mV	3mV	8mV	12mV	16mV
Current Programmable Resolution	1mA	1mA	1mA	1mA	1mA
Voltage Setting Accuracy ^[1]	0.1%+15mV	0.1%+15mV	0.05%+100mV	0.05%+150mV	0.05%+200mV
Current Setting Accuracy	0.1%+10mA	0.1%+8mA	0.1%+15mA	0.1%+10mA	0.1%+10mA
Voltage Measurement Accuracy ^[1]	0.1%+15mV	0.1%+15mV	0.05%+100mV	0.05%+150mV	0.05%+200mV
Current Measurement Accuracy	0.1%+10mA	0.1%+8mA	0.1%+15mA	0.1%+10mA	0.1%+10mA
Voltage Ripple ^[2]	120mVp-p 40mVrms	120mVp-p 40mVrms	350mVp-p 40mVrms	350mVp-p 40mVrms	500mVp-p 60mVrms
Current Ripple ^[3]	40mA (Full Range) 10mA (TYP Value)	40mA (Full Range) 10mA (TYP Value)	25mA (Full Range) 10mA (TYP Value)	25mA (Full Range) 10mA (TYP Value)	25mA (Full Range) 10mA (TYP Value)
Line Regulation (Voltage)	0.02%+8mV	0.02%+8mV	0.02%+20mV	0.02%+30mV	0.02%+40mV
Line Regulation (Current)	10mA	30mA	10mA	8mA	10mA
Voltage Temperature Coefficient ^[4]	100ppm/°C	100ppm/°C	100ppm/°C	100ppm/°C	100ppm/°C
Current Temperature Coefficient ^[4]	150ppm/°C	150ppm/°C	150ppm/°C	150ppm/°C	150ppm/°C
DVM Resolution	1mV	1mV	8mV	12mV	16mV
DVM Precision ^[1]	0.1%+15mV	0.1%+15mV	0.05%+100mV	0.05%+150mV	0.05%+200mV
Operating Mode	Constant voltage (CV) / Constant current (CC)				
Remote Compensation	4V MAX	4V MAX	4V MAX	4V MAX	4V MAX
Master-slave Control	Yes	Yes	Yes	Yes	Yes

Model	SP150VDC1500W	SP200VDC1500W	SP400VDC1500W	SP600VDC1500W	SP800VDC1500W
Response (Voltage Increase)	≤25ms	≤30ms	≤60ms	≤60ms	≤60ms
Response (Voltage Drop)	≤400ms (no load) ≤18ms (full load)	≤600ms (no load) ≤30ms (full load)	≤800ms (no load) ≤60ms (full load)	≤1200ms (no load) ≤60ms (full load)	≤1200ms (no load) ≤60ms (full load)
Load Transient Recovery Time ^[5]	≤2ms	≤3ms	≤3ms	≤3ms	≤3ms
Command Response Time	50ms				
Series Capability ^[6]	Up to 8 units	Up to 6 units	Up to 3 units	Up to 2 units	Not Recommended
Parallel Capability	Up to 10 units	Up to 10 units	Up to 10 units	Up to 10 units	Up to 10 units
Current Sharing ^[7]	40V	50V	120V	200V	250V
Efficiency (full load)	90%	91%	91%	91%	91%
Protection Function	OVP/OCP/OTP/OPP/SCP				
Input Fuse	30A, 125VAC/250VAC, fast-acting type				
Net Weight	9.3kg	9.3kg	9.5kg	9.5kg	9.5kg
Accessories Weight	1.0kg	1.0kg	1.0kg	1.0kg	1.0kg
Dimensions(WxHxD)	483.0x44.0x531.0 mm				
Communication Modes	1. RS232/RS485/USB/LAN; 2. RS232/RS485/USB/LAN/GPIB				
Operating Environment	Temperature 0~40°C. Relative Humidity 10%~90%(no condensation); Pollution degree 2, Installation category II, Indoor use.				
Cooling Mode	Forced air-cooling				
Altitude	2000m				

[1] %output+offset, when output voltage less than 5V, offset voltage is 30mV.

[2] Vp-p@20MHz, Vrms@1.25MHz.

[3] Arms@1.25MHz, the TYP Value is measured at the rated output voltage with 100% resistive load, and the measured value at full range of output voltage with 100% resistive load is less than the Full Range value.

[4] 0~40°C.

[5] Time for output voltage to recover within 0.5% of its rated output for a load change from 10% to 90% of its rated output current. Voltage set point from 10% to 90% of rated output.

[6] The communication must insulated users from output when using remote control and the output voltage exceeds 800VDC.

[7] Current Share error $I_e < (I_{av} \cdot 2.5\% + 1) A$, $I_{av} = I_{sum}/n$, where I_{av} is average current, I_{sum} is total current and n is number of parallel units.
Note: Output voltage must be higher than 30% of maximum output voltage when Current Share function properly.

All specifications are subject to change without notice. Please visit our website for the most up to date specifications.

● **1000W in 2U**

Model	SPS20VDC1000W	SPS40VDC1000W	SPS75VDC1000W	SPS120VDC1000W	SPS150VDC1000W
Input Voltage	100~240VAC (90~265VAC range), Installation category II				
Input Frequency	50/60Hz (47~63Hz range)				
Power Factor	>0.97	>0.97	>0.97	>0.98	>0.98
Input Power	1400VA(MAX)	1300VA(MAX)	1300VA(MAX)	1300VA(MAX)	1300VA(MAX)
Output Voltage Range	0~20V	0~40V	0~75V	0~120V	0~150V
Output Current Range	0~200A	0~120A	0~50A	0~40A	0~30A
Output Power Range	0~1000W	0~1000W	0~1000W	0~1000W	0~1000W
Voltage Load Regulation	15mV	15mV	15mV	15mV	15mV
Current Load Regulation	200mA	120mA	50mA	40mA	30mA
Voltage Display Resolution	0.1mV	0.1mV	0.1mV	1mV	1mV
Current Display Resolution	1mA	1mA	0.1mA	0.1mA	0.1mA
Voltage Programmable Resolution	1mV	1mV	2mV	3mV	3mV
Current Programmable Resolution	3mA	3mA	2mA	1mA	1mA
Voltage Setting Accuracy ^[1]	0.05%+15mV	0.05%+15mV	0.05%+15mV	0.1%+15mV	0.1%+15mV
Current Setting Accuracy	0.1%+200mA	0.1%+120mA	0.1%+50mA	0.1%+40mA	0.1%+30mA
Voltage Measurement Accuracy ^[1]	0.05%+15mV	0.05%+15mV	0.05%+15mV	0.1%+15mV	0.1%+15mV
Current Measurement Accuracy	0.1%+200mA	0.1%+120mA	0.1%+50mA	0.1%+40mA	0.1%+30mA
Voltage Ripple ^[2]	40mVp-p 6mVrms	40mVp-p 6mVrms	40mVp-p 6mVrms	80mVp-p 15mVrms	80mVp-p 15mVrms
Current Ripple ^[3]	150mA (Full Range) 40mA (TYP Value)	150mA (Full Range) 20mA (TYP Value)	50mA (Full Range) 10mA (TYP Value)	60mA (Full Range) 10mA (TYP Value)	60mA (Full Range) 10mA (TYP Value)
Line Regulation (Voltage)	0.02%+8mV	0.02%+8mV	0.02%+8mV	0.02%+8mV	0.02%+8mV
Line Regulation (Current)	30mA	30mA	30mA	40mA	30mA
Voltage Temperature Coefficient ^[4]	100ppm/°C	100ppm/°C	100ppm/°C	100ppm/°C	100ppm/°C
Current Temperature Coefficient ^[4]	150ppm/°C	150ppm/°C	150ppm/°C	150ppm/°C	150ppm/°C
DVM Resolution	0.1mV	0.1mV	0.1mV	1mV	1mV
DVM Precision ^[1]	0.05%+15mV	0.05%+15mV	0.05%+15mV	0.1%+15mV	0.1%+15mV
Operating Mode	Constant voltage (CV) / Constant current (CC)				
Remote Compensation	4V MAX	4V MAX	5V MAX	4V MAX	4V MAX
Master-slave Control	Yes	Yes	Yes	Yes	Yes

Model	SPS20VDC1000W	SPS40VDC1000W	SPS75VDC1000W	SPS120VDC1000W	SPS150VDC1000W
Response (Voltage Increase)	≤10ms	≤10ms	≤15ms	≤20ms	≤25ms
Response (Voltage Drop)	≤200ms (no load) ≤20ms (full load)	≤350ms (no load) ≤30ms (full load)	≤450ms (no load) ≤60ms (full load)	≤350ms (no load) ≤30ms (full load)	≤500ms (no load) ≤35ms (full load)
Load Transient Recovery Time ^[5]	≤2ms	≤2ms	≤2ms	≤2ms	≤2ms
Command Response Time	50ms				
Series Capability ^[6]	Up to 10 units	Up to 10 units	Up to 10 units	Up to 10 units	Up to 8 units
Parallel Capability	Up to 10 units	Up to 10 units	Up to 10 units	Up to 10 units	Up to 10 units
Current Sharing ^[7]	12V	12V	20V	30V	40V
Efficiency (full load)	86%	87%	88%	88%	88%
Protection Function	OVP/OCP/OTP/OPP/SCP				
Input Fuse	30A, 125VAC/250VAC, fast-acting type				
Net Weight	14.7kg	14.7kg	13.2kg	13.2kg	13.2kg
Accessories Weight	1.0kg	1.0kg	1.0kg	1.0kg	1.0kg
Dimensions(WxHxD)	483.0x87.0x626.0 mm		483.0x87.0x581.0 mm		
Communication Modes	1. RS232/RS485/USB/LAN; 2. RS232/RS485/USB/LAN/GPIB				
Operating Environment	Temperature 0~40°C. Relative Humidity 10%~90%(no condensation); Pollution degree 2, Installation category II, Indoor use.				
Cooling Mode	Forced air-cooling				
Altitude	2000m				

[1] %output+offset, when output voltage less than 5V, offset voltage is 30mV.

[2] Vp-p@20MHz, Vrms@1.25MHz.

[3] Arms@1.25MHz, the TYP Value is measured at the rated output voltage with 100% resistive load, and the measured value at full range of output voltage with 100% resistive load is less than the Full Range value.

[4] 0~40°C.

[5] Time for output voltage to recover within 0.5% of its rated output for a load change from 10% to 90% of its rated output current. Voltage set point from 10% to 90% of rated output.

[6] The communication must insulated users from output when using remote control and the output voltage exceeds 800VDC.

[7] Current Share error $I_e < (I_{av} * 2.5\% + 1) A$, $I_{av} = I_{sum} / n$, where I_{av} is average current, I_{sum} is total current and n is number of parallel units.
Note: Output voltage must be higher than 30% of maximum output voltage when Current Share function properly.

All specifications are subject to change without notice. Please visit our website for the most up to date specifications.

● **1000W in 2U**

Model	SPS200VDC1000W	SPS400VDC1000W	SPS600VDC1000W	SPS800VDC1000W
Input Voltage	100~240VAC (90~265VAC range), Installation category II			
Input Frequency	50/60Hz (47~63Hz range)			
Power Factor	>0.98			
Input Power	1300VA(MAX)	1300VA(MAX)	1300VA(MAX)	1300VA(MAX)
Output Voltage Range	0~200V	0~400V	0~600V	0~800V
Output Current Range	0~24A	0~15A	0~10A	0~4A
Output Power Range	0~1000W	0~1000W	0~1000W	0~1000W
Voltage Load Regulation	15mV	30mV	30mV	40mV
Current Load Regulation	24mA	15mA	10mA	8mA
Voltage Display Resolution	1mV	1mV	1mV	1mV
Current Display Resolution	0.1mA	0.1mA	0.1mA	0.1mA
Voltage Programmable Resolution	4mV	8mV	12mV	16mV
Current Programmable Resolution	1mA	1mA	1mA	1mA
Voltage Setting Accuracy ^[1]	0.1%+15mV	0.05%+100mV	0.05%+150mV	0.05%+200mV
Current Setting Accuracy	0.1%+24mA	0.1%+15mA	0.1%+10mA	0.1%+8mA
Voltage Measurement Accuracy ^[1]	0.1%+15mV	0.05%+100mV	0.05%+150mV	0.05%+200mV
Current Measurement Accuracy	0.1%+24mA	0.1%+15mA	0.1%+10mA	0.1%+8mA
Voltage Ripple ^[2]	150mVp-p 30mVrms	350mVp-p 40mVrms	350mVp-p 40mVrms	500mVp-p 60mVrms
Current Ripple ^[3]	50mA (Full Range) 20mA (TYP Value)	25mA (Full Range) 10mA (TYP Value)	25mA (Full Range) 10mA (TYP Value)	25mA (Full Range) 10mA (TYP Value)
Line Regulation (Voltage)	0.02%+8mV	0.01%+20mV	0.01%+30mV	0.01%+40mV
Line Regulation (Current)	30mA	15mA	15mA	15mA
Voltage Temperature Coefficient ^[4]	100ppm/°C	100ppm/°C	100ppm/°C	100ppm/°C
Current Temperature Coefficient ^[4]	150ppm/°C	150ppm/°C	150ppm/°C	150ppm/°C
DVM Resolution	1mV	8mV	12mV	16mV
DVM Precision ^[1]	0.1%+15mV	0.05%+100mV	0.05%+150mV	0.05%+200mV
Operating Mode	Constant voltage (CV) / Constant current (CC)			
Remote Compensation	5V MAX	5V MAX	5V MAX	5V MAX
Master-slave Control	Yes	Yes	Yes	Yes

Model	SPS200VDC1000W	SPS400VDC1000W	SPS600VDC1000W	SPS800VDC1000W
Response (Voltage Increase)	≤30ms	≤60ms	≤60ms	≤60ms
Response (Voltage Drop)	≤500ms (no load) ≤35ms (full load)	≤1200ms (no load) ≤110ms (full load)	≤1200ms (no load) ≤110ms (full load)	≤1200ms (no load) ≤110ms (full load)
Load Transient Recovery Time ^[5]	≤2ms	≤3ms	≤3ms	≤3ms
Command Response Time	50ms			
Series Capability ^[6]	Up to 6 units	Up to 3 units	Up to 2 units	Not Recommended
Parallel Capability	Up to 10 units	Up to 10 units	Up to 10 units	Up to 10 units
Current Sharing ^[7]	50V	120V	200V	250V
Efficiency (full load)	88%	86%	86%	86%
Protection Function	OVP/OCP/OTP/OPP/SCP			
Input Fuse	30A, 125VAC/250 VAC, fast-acting type	20A, 125VAC/250 VAC, fast-acting type	20A, 125VAC/250 VAC, fast-acting type	20A, 125VAC/250 VAC, fast-acting type
Net Weight	13.2kg	14.7kg	14.7kg	14.7kg
Accessories Weight	1.0kg	1.0kg	1.0kg	1.0kg
Dimensions(WxHxD)	483.0x87.0x581.0 mm			
Communication Modes	1. RS232/RS485/USB/LAN; 2. RS232/RS485/USB/LAN/GPIB			
Operating Environment	Temperature 0~40°C. Relative Humidity 10%~90%(no condensation); Pollution degree 2, Installation category II, Indoor use.			
Cooling Mode	Forced air-cooling			
Altitude	2000m			

[1] %output+offset, when output voltage less than 5V, offset voltage is 30mV.

[2] Vp-p@20MHz, Vrms@1.25MHz.

[3] Arms@1.25MHz, the TYP Value is measured at the rated output voltage with 100% resistive load, and the measured value at full range of output voltage with 100% resistive load is less than the Full Range value.

[4] 0~40°C.

[5] Time for output voltage to recover within 0.5% of its rated output for a load change from 10% to 90% of its rated output current. Voltage set point from 10% to 90% of rated output.

[6] The communication must insulated users from output when using remote control and the output voltage exceeds 800VDC.

[7] Current Share error $I_e < (I_{av} \cdot 2.5\% + 1) A$, $I_{av} = I_{sum} / n$, where I_{av} is average current, I_{sum} is total current and n is number of parallel units.

Note: Output voltage must be higher than 30% of maximum output voltage when Current Share function properly.

All specifications are subject to change without notice. Please visit our website for the most up to date specifications.

● **2000W in 2U**

Model	SP20VDC2000W	SP40VDC2000W	SP75VDC2000W	SP80VDC2000W	SP120VDC2000W
Input Voltage	208~240VAC (190~265VAC range), Installation category II				
Input Frequency	50/60Hz (47~63Hz range)				
Power Factor	>0.98				
Input Power	2400VA(MAX)	2400VA(MAX)	2400VA(MAX)	2400VA(MAX)	2400VA(MAX)
Output Voltage Range	0~20V	0~40V	0~75V	0~80V	0~120V
Output Current Range	0~200A	0~120A	0~50A	0~60A	0~40A
Output Power Range	0~2000W	0~2000W	0~2000W	0~2000W	0~2000W
Voltage Load Regulation	15mV	15mV	15mV	15mV	15mV
Current Load Regulation	200mA	120mA	50mA	60mA	40mA
Voltage Display Resolution	0.1mV	0.1mV	0.1mV	0.1mV	1mV
Current Display Resolution	1mA	1mA	0.1mA	0.1mA	0.1mA
Voltage Programmable Resolution	1mV	1mV	2mV	2mV	3mV
Current Programmable Resolution	3mA	3mA	2mA	2mA	1mA
Voltage Setting Accuracy ^[1]	0.05%+15mV	0.05%+15mV	0.05%+15mV	0.1%+15mV	0.1%+15mV
Current Setting Accuracy	0.1%+200mA	0.1%+120mA	0.1%+50mA	0.1%+60mA	0.1%+40mA
Voltage Measurement Accuracy ^[1]	0.05%+15mV	0.05%+15mV	0.05%+15mV	0.1%+15mV	0.1%+15mV
Current Measurement Accuracy	0.1%+200mA	0.1%+120mA	0.1%+50mA	0.1%+60mA	0.1%+40mA
Voltage Ripple ^[2]	40mVp-p 6mVrms	40mVp-p 6mVrms	40mVp-p 6mVrms	40mVp-p 6mVrms	80mVp-p 15mVrms
Current Ripple ^[3]	150mA (Full Range) 40mA (TYP Value)	150mA (Full Range) 20mA (TYP Value)	50mA (Full Range) 10mA (TYP Value)	50mA (Full Range) 10mA (TYP Value)	60mA (Full Range) 10mA (TYP Value)
Line Regulation (Voltage)	0.01%+8mV	0.01%+8mV	0.01%+8mV	0.01%+8mV	0.02%+8mV
Line Regulation (Current)	30mA	30mA	30mA	30mA	30mA
Voltage Temperature Coefficient ^[4]	100ppm/°C	100ppm/°C	100ppm/°C	100ppm/°C	100ppm/°C
Current Temperature Coefficient ^[4]	150ppm/°C	150ppm/°C	150ppm/°C	150ppm/°C	150ppm/°C
DVM Resolution	0.1mV	0.1mV	0.1mV	0.1mV	1mV
DVM Precision ^[1]	0.05%+15mV	0.05%+15mV	0.05%+15mV	0.05%+15mV	0.1%+15mV
Operating Mode	Constant voltage (CV) / Constant current (CC)				
Remote Compensation	4V MAX	4V MAX	4V MAX	4V MAX	5V MAX
Master-slave Control	Yes	Yes	Yes	Yes	Yes

Model	SP20VDC2000W	SP40VDC2000W	SP75VDC2000W	SP80VDC2000W	SP120VDC2000W
Response (Voltage Increase)	≤10ms	≤10ms	≤15ms	≤15ms	≤20ms
Response (Voltage Drop)	≤200ms (no load) ≤15ms (full load)	≤350ms (no load) ≤18ms (full load)	≤450ms (no load) ≤30ms (full load)	≤450ms (no load) ≤30ms (full load)	≤350ms (no load) ≤27ms (full load)
Load Transient Recovery Time ^[5]	≤2ms	≤2ms	≤2ms	≤3ms	≤3ms
Command Response Time	50ms				
Series Capability ^[6]	Up to 10 units	Up to 10 units	Up to 10 units	Up to 10 units	Up to 10 units
Parallel Capability	Up to 10 units	Up to 10 units	Up to 10 units	Up to 10 units	Up to 10 units
Current Sharing ^[7]	12V	12V	20V	20V	30V
Efficiency (full load)	86%	88%	88%	89%	89%
Protection Function	OVP/OCP/OTP/OPP/SCP				
Input Fuse	30A, 125VAC/250VAC, fast-acting type				
Net Weight	14.7kg	14.7kg	13.2kg	13.2kg	13.2kg
Accessories Weight	1.0kg	1.0kg	1.0kg	1.0kg	1.0kg
Dimensions(WxHxD)	483.0x87.0x626.0 mm		483.0x87.0x581.0 mm		
Communication Modes	1. RS232/RS485/USB/LAN; 2. RS232/RS485/USB/LAN/GPIB				
Operating Environment	Temperature 0~40°C. Relative Humidity 10%~90%(no condensation); Pollution degree 2, Installation category II, Indoor use.				
Cooling Mode	Forced air-cooling				
Altitude	2000m				

[1] %output+offset, when output voltage less than 5V, offset voltage is 30mV.

[2] Vp-p@20MHz, Vrms@1.25MHz.

[3] Arms@1.25MHz, the TYP Value is measured at the rated output voltage with 100% resistive load, and the measured value at full range of output voltage with 100% resistive load is less than the Full Range value.

[4] 0~40°C.

[5] Time for output voltage to recover within 0.5% of its rated output for a load change from 10% to 90% of its rated output current. Voltage set point from 10% to 90% of rated output.

[6] The communication must insulated users from output when using remote control and the output voltage exceeds 800VDC.

[7] Current Share error $I_e < (I_{av} * 2.5\% + 1) A$, $I_{av} = I_{sum} / n$, where I_{av} is average current, I_{sum} is total current and n is number of parallel units.
Note: Output voltage must be higher than 30% of maximum output voltage when Current Share function properly.

All specifications are subject to change without notice. Please visit our website for the most up to date specifications.

● **2000W in 2U**

Model	SP150VDC2000W	SP200VDC2000W	SP400VDC2000W	SP600VDC2000W	SP800VDC2000W
Input Voltage	208~240VAC (190~265VAC range), Installation category II				
Input Frequency	50/60Hz (47~63Hz range)				
Power Factor	>0.98				
Input Power	2400VA(MAX)	2400VA(MAX)	2400VA(MAX)	2400VA(MAX)	2400VA(MAX)
Output Voltage Range	0~150V	0~200V	0~400V	0~600V	0~800V
Output Current Range	0~30A	0~24A	0~15A	0~10A	0~7.5A
Output Power Range	0~2000W	0~2000W	0~2000W	0~2000W	0~2000W
Voltage Load Regulation	15mV	15mV	15mV	30mV	40mV
Current Load Regulation	30mA	24mA	15mA	30mA	20mA
Voltage Display Resolution	1mV	1mV	1mV	1mV	1mV
Current Display Resolution	0.1mA	0.1mA	0.1mA	0.1mA	0.1mA
Voltage Programmable Resolution	3mV	4mV	8mV	12mV	16mV
Current Programmable Resolution	1mA	1mA	1mA	1mA	1mA
Voltage Setting Accuracy ^[1]	0.1%+15mV	0.1%+15mV	0.05%+100mV	0.05%+150mV	0.05%+200mV
Current Setting Accuracy	0.1%+30mA	0.1%+24mA	0.1%+15mA	0.1%+10mA	0.1%+10mA
Voltage Measurement Accuracy ^[1]	0.1%+15mV	0.1%+15mV	0.05%+100mV	0.05%+150mV	0.1%+200mV
Current Measurement Accuracy	0.1%+30mA	0.1%+24mA	0.1%+15mA	0.1%+10mA	0.1%+10mA
Voltage Ripple ^[2]	80mVp-p 15mVrms	150mVp-p 30mVrms	350mVp-p 40mVrms	350mVp-p 40mVrms	500mVp-p 60mVrms
Current Ripple ^[3]	60mA (Full Range) 10mA (TYP Value)	50mA (Full Range) 20mA (TYP Value)	25mA (Full Range) 10mA (TYP Value)	25mA (Full Range) 10mA (TYP Value)	25mA (Full Range) 10mA (TYP Value)
Line Regulation (Voltage)	0.02%+8mV	0.02%+8mV	0.01%+20mV	0.01%+30mV	0.01%+40mV
Line Regulation (Current)	30mA	30mA	24mA	15mA	20mA
Voltage Temperature Coefficient ^[4]	100ppm/°C	100ppm/°C	100ppm/°C	100ppm/°C	100ppm/°C
Current Temperature Coefficient ^[4]	150ppm/°C	150ppm/°C	150ppm/°C	150ppm/°C	150ppm/°C
DVM Resolution	1mV	1mV	8mV	12mV	16mV
DVM Precision ^[1]	0.1%+15mV	0.1%+15mV	0.05%+100mV	0.05%+150mV	0.05%+200mV
Operating Mode	Constant voltage (CV) / Constant current (CC)				
Remote Compensation	5V MAX	5V MAX	5V MAX	5V MAX	5V MAX
Master-slave Control	Yes	Yes	Yes	Yes	Yes

Model	SP150VDC2000W	SP200VDC2000W	SP400VDC2000W	SP600VDC2000W	SP800VDC2000W
Response (Voltage Increase)	≤25ms	≤30ms	≤60ms	≤60ms	≤60ms
Response (Voltage Drop)	≤500ms (no load) ≤36ms (full load)	≤500ms (no load) ≤30ms (full load)	≤1200ms (no load) ≤90ms (full load)	≤1200ms (no load) ≤90ms (full load)	≤1200ms (no load) ≤90ms (full load)
Load Transient Recovery Time ^[5]	≤3ms	≤3ms	≤3ms	≤3ms	≤3ms
Command Response Time	50ms				
Series Capability ^[6]	Up to 8 units	Up to 6 units	Up to 3 units	Up to 2 units	Not Recommended
Parallel Capability	Up to 10 units	Up to units	Up to 10 units	Up to 10 units	Up to 10 units
Current Sharing ^[7]	40V	50V	120V	200V	250V
Efficiency (full load)	90%	90%	91%	91%	91%
Protection Function	OVP/OCP/OTP/OPP/SCP				
Input Fuse	30A, 125VAC/250 VAC, fast-acting type	30A, 125VAC/250 VAC, fast-acting type	20A, 125VAC/250 VAC, fast-acting type	20A, 125VAC/250 VAC, fast-acting type	20A, 125VAC/250 VAC, fast-acting type
Net Weight	13.2kg	13.2kg	14.7kg	14.7kg	14.7kg
Accessories Weight	1.0kg	1.0kg	1.0kg	1.0kg	1.0kg
Dimensions(WxHxD)	483.0x87.0x581.0 mm				
Communication Modes	1. RS232/RS485/USB/LAN; 2. RS232/RS485/USB/LAN/GPIB				
Operating Environment	Temperature 0~40°C, Relative Humidity 10%~90%(no condensation); Pollution degree 2, Installation category II, Indoor use.				
Cooling Mode	Forced air-cooling				
Altitude	2000m				

[1] %output+offset, when output voltage less than 5V, offset voltage is 30mV.

[2] Vp-p@20MHz, Vrms@1.25MHz.

[3] Arms@1.25MHz, the TYP Value is measured at the rated output voltage with 100% resistive load, and the measured value at full range of output voltage with 100% resistive load is less than the Full Range value.

[4] 0~40°C.

[5] Time for output voltage to recover within 0.5% of its rated output for a load change from 10% to 90% of its rated output current. Voltage set point from 10% to 90% of rated output.

[6] The communication must insulated users from output when using remote control and the output voltage exceeds 800VDC.

[7] Current Share error $I_e < (I_{av} \cdot 2.5\% + 1) A$, $I_{av} = I_{sum}/n$, where I_{av} is average current, I_{sum} is total current and n is number of parallel units.

Note: Output voltage must be higher than 30% of maximum output voltage when Current Share function properly.

All specifications are subject to change without notice. Please visit our website for the most up to date specifications.

● 3000W in 2U

Model	SP20VDC3000W	SP32VDC3000W	SP40VDC3000W	SP75VDC3000W	SP80VDC3000W
Input Voltage	208~240VAC (190~265VAC range), Installation category II				
Input Frequency	50/60Hz (47~63Hz range)				
Power Factor	>0.98				
Input Power	3400VA(MAX)	3400VA(MAX)	3400VA(MAX)	3400VA(MAX)	3400VA(MAX)
Output Voltage Range	0~20V	0~32V	0~40V	0~75V	0~80V
Output Current Range	0~200A	0~120A	0~120A	0~50A	0~60A
Output Power Range	0~3000W	0~3000W	0~3000W	0~3000W	0~3000W
Voltage Load Regulation	15mV	15mV	15mV	15mV	15mV
Current Load Regulation	200mA	120mA	120mA	50mA	60mA
Voltage Display Resolution	0.1mV	0.1mV	0.1mV	0.1mV	0.1mV
Current Display Resolution	1mA	1mA	1mA	0.1mA	0.1mA
Voltage Programmable Resolution	1mV	1mV	1mV	2mV	2mV
Current Programmable Resolution	3mA	3mA	3mA	2mA	2mA
Voltage Setting Accuracy ^[1]	0.05%+15mV	0.05%+15mV	0.05%+15mV	0.05%+15mV	0.05%+15mV
Current Setting Accuracy	0.1%+200mA	0.1%+120mA	0.1%+120mA	0.1%+50mA	0.1%+60mA
Voltage Measurement Accuracy ^[1]	0.05%+15mV	0.05%+15mV	0.05%+15mV	0.05%+15mV	0.05%+15mV
Current Measurement Accuracy	0.1%+200mA	0.1%+120mA	0.1%+120mA	0.1%+50mA	0.1%+60mA
Voltage Ripple ^[2]	40mVp-p 6mVrms	40mVp-p 6mVrms	40mVp-p 6mVrms	40mVp-p 6mVrms	40mVp-p 6mVrms
Current Ripple ^[3]	300mA (Full Range) 80mA (TYP Value)	150mA (Full Range) 20mA (TYP Value)	150mA (Full Range) 20mA (TYP Value)	50mA (Full Range) 10mA (TYP Value)	50mA (Full Range) 10mA (TYP Value)
Line Regulation (Voltage)	0.01%+8mV	0.01%+8mV	0.01%+8mV	0.01%+8mV	0.01%+8mV
Line Regulation (Current)	30mA	30mA	30mA	30mA	30mA
Voltage Temperature Coefficient ^[4]	100ppm/°C	100ppm/°C	100ppm/°C	100ppm/°C	100ppm/°C
Current Temperature Coefficient ^[4]	150ppm/°C	150ppm/°C	150ppm/°C	150ppm/°C	150ppm/°C
DVM Resolution	0.1mV	0.1mV	0.1mV	0.1mV	0.1mV
DVM Precision ^[1]	0.05%+15mV	0.05%+15mV	0.05%+15mV	0.05%+15mV	0.05%+15mV
Operating Mode	Constant voltage (CV) / Constant current (CC)				
Remote Compensation	4V MAX	4V MAX	4V MAX	5V MAX	4V MAX
Master-slave Control	Yes	Yes	Yes	Yes	Yes

Model	SP20VDC3000W	SP32VDC3000W	SP40VDC3000W	SP75VDC3000W	SP80VDC3000W
Response (Voltage Increase)	≤10ms	≤10ms	≤10ms	≤15ms	≤15ms
Response (Voltage Drop)	≤300ms (no load) ≤12ms (full load)	≤350ms (no load) ≤12ms (full load)	≤350ms (no load) ≤12ms (full load)	≤450ms (no load) ≤25ms (full load)	≤450ms (no load) ≤30ms (full load)
Load Transient Recovery Time ^[5]	≤2ms	≤2ms	≤2ms	≤2ms	≤2ms
Command Response Time	50ms				
Series Capability ^[6]	Up to 10 units	Up to 10 units	Up to 10 units	Up to 10 units	Up to 10 units
Parallel Capability	Up to 10 units	Up to 10 units	Up to 10 units	Up to 10 units	Up to 10 units
Current Sharing ^[7]	12V	12V	12V	20V	20V
Efficiency (full load)	86%	86%	88%	91%	91%
Protection Function	OVP/OCP/OTP/OPP/SCP				
Input Fuse	40A, 125VAC/250VAC, fast-acting type				
Net Weight	14.7kg	14.7kg	14.7kg	13.2kg	13.2kg
Accessories Weight	1.0kg	1.0kg	1.0kg	1.0kg	1.0kg
Dimensions(WxHxD)	483.0x87.0x626.0 mm			483.0x87.0x581.0 mm	
Communication Modes	1. RS232/RS485/USB/LAN; 2. RS232/RS485/USB/LAN/GPIB				
Operating Environment	Temperature 0~40°C. Relative Humidity 10%~90%(no condensation); Pollution degree 2, Installation category II, Indoor use.				
Cooling Mode	Forced air-cooling				
Altitude	2000m				

[1] %output+offset, when output voltage less than 5V, offset voltage is 30mV.

[2] Vp-p@20MHz, Vrms@1.25MHz.

[3] Arms@1.25MHz, the TYP Value is measured at the rated output voltage with 100% resistive load, and the measured value at full range of output voltage with 100% resistive load is less than the Full Range value.

[4] 0~40°C.

[5] Time for output voltage to recover within 0.5% of its rated output for a load change from 10% to 90% of its rated output current. Voltage set point from 10% to 90% of rated output.

[6] The communication must insulated users from output when using remote control and the output voltage exceeds 800VDC.

[7] Current Share error $I_e < (I_{av} * 2.5\% + 1) A$, $I_{av} = I_{sum} / n$, where I_{av} is average current, I_{sum} is total current and n is number of parallel units.
Note: Output voltage must be higher than 30% of maximum output voltage when Current Share function properly.

All specifications are subject to change without notice. Please visit our website for the most up to date specifications.

● **3000W in 2U**

Model	SP120VDC3000W	SP150VDC3000W	SP200VDC3000W	SP400VDC3000W	SP600VDC3000W
Input Voltage	208~240VAC (190~265VAC range), Installation category II				
Input Frequency	50/60Hz (47~63Hz range)				
Power Factor	>0.98				
Input Power	3400VA(MAX)	3400VA(MAX)	3400VA(MAX)	3400VA(MAX)	3400VA(MAX)
Output Voltage Range	0~120V	0~150V	0~200V	0~400V	0~600V
Output Current Range	0~40A	0~30A	0~24A	0~15A	0~10A
Output Power Range	0~3000W	0~3000W	0~3000W	0~3000W	0~3000W
Voltage Load Regulation	15mV	15mV	15mV	30mV	30mV
Current Load Regulation	40mA	30mA	24mA	15mA	10mA
Voltage Display Resolution	1mV	1mV	1mV	1mV	1mV
Current Display Resolution	0.1mA	0.1mA	0.1mA	0.1mA	0.1mA
Voltage Programmable Resolution	3mV	3mV	4mV	8mV	12mV
Current Programmable Resolution	1mA	1mA	1mA	1mA	1mA
Voltage Setting Accuracy ^[1]	0.1%+15mV	0.1%+15mV	0.1%+15mV	0.05%+100mV	0.05%+150mV
Current Setting Accuracy	0.1%+40mA	0.1%+30mA	0.1%+24mA	0.1%+15mA	0.1%+10mA
Voltage Measurement Accuracy ^[1]	0.1%+15mV	0.1%+15mV	0.1%+15mV	0.05%+100mV	0.05%+150mV
Current Measurement Accuracy	0.1%+40mA	0.1%+30mA	0.1%+24mA	0.1%+15mA	0.1%+10mA
Voltage Ripple ^[2]	80mVp-p 15mVrms	80mVp-p 15mVrms	150mVp-p 30mVrms	350mVp-p 40mVrms	350mVp-p 40mVrms
Current Ripple ^[3]	60mA (Full Range) 10mA (TYP Value)	60mA (Full Range) 10mA (TYP Value)	50mA (Full Range) 20mA (TYP Value)	25mA (Full Range) 10mA (TYP Value)	25mA (Full Range) 10mA (TYP Value)
Line Regulation (Voltage)	0.02%+8mV	0.02%+8mV	0.02%+8mV	0.01%+20mV	0.01%+30mV
Line Regulation (Current)	30mA	30mA	30mA	24mA	15mA
Voltage Temperature Coefficient ^[4]	100ppm/°C	100ppm/°C	100ppm/°C	100ppm/°C	100ppm/°C
Current Temperature Coefficient ^[4]	150ppm/°C	150ppm/°C	150ppm/°C	150ppm/°C	150ppm/°C
DVM Resolution	1mV	1mV	1mV	8mV	12mV
DVM Precision ^[1]	0.1%+15mV	0.1%+15mV	0.1%+15mV	0.05%+100mV	0.05%+150mV
Operating Mode	Constant voltage (CV) / Constant current (CC)				
Remote Compensation	5V MAX	5V MAX	5V MAX	5V MAX	5V MAX
Master-slave Control	Yes	Yes	Yes	Yes	Yes

Model	SP120VDC3000W	SP150VDC3000W	SP200VDC3000W	SP400VDC3000W	SP600VDC3000W
Response (Voltage Increase)	≤20ms	≤25ms	≤30ms	≤60ms	≤60ms
Response (Voltage Drop)	≤350ms (no load) ≤21ms (full load)	≤500ms (no load) ≤25ms (full load)	≤500ms (no load) ≤25ms (full load)	≤1200ms (no load) ≤75ms (full load)	≤1200ms (no load) ≤75ms (full load)
Load Transient Recovery Time ^[5]	≤2ms	≤2.5ms	≤3ms	≤3ms	≤3ms
Command Response Time	50ms				
Series Capability ^[6]	Up to 10 units	Up to 8 units	Up to 6 units	Up to 3 units	Up to 2 units
Parallel Capability	Up to 10 units	Up to 10 units	Up to 10 units	Up to 10 units	Up to 10 units
Current Sharing ^[7]	30V	40V	50V	120V	200V
Efficiency (full load)	91%	92%	91%	91%	91%
Protection Function	OVP/OCP/OTP/OPP/SCP				
Input Fuse	40A, 125VAC/250 VAC, fast-acting type	40A, 125VAC/250 VAC, fast-acting type	40A, 125VAC/250 VAC, fast-acting type	30A, 125VAC/250 VAC, fast-acting type	30A, 125VAC/250 VAC, fast-acting type
Net Weight	13.2kg	13.2kg	13.2kg	14.7kg	14.7kg
Accessories Weight	1.0kg	1.0kg	1.0kg	1.0kg	1.0kg
Dimensions(WxHxD)	483.0x87.0x581.0 mm				
Communication Modes	1. RS232/RS485/USB/LAN; 2. RS232/RS485/USB/LAN/GPIB				
Operating Environment	Temperature 0~40°C, Relative Humidity 10%~90%(no condensation); Pollution degree 2, Installation category II, Indoor use.				
Cooling Mode	Forced air-cooling				
Altitude	2000m				

[1] %output+offset, when output voltage less than 5V, offset voltage is 30mV.

[2] Vp-p@20MHz, Vrms@1.25MHz.

[3] Arms@1.25MHz, the TYP Value is measured at the rated output voltage with 100% resistive load, and the measured value at full range of output voltage with 100% resistive load is less than the Full Range value.

[4] 0~40°C.

[5] Time for output voltage to recover within 0.5% of its rated output for a load change from 10% to 90% of its rated output current. Voltage set point from 10% to 90% of rated output.

[6] The communication must insulated users from output when using remote control and the output voltage exceeds 800VDC.

[7] Current Share error $I_e < (I_{av} \cdot 2.5\% + 1) A$, $I_{av} = I_{sum}/n$, where I_{av} is average current, I_{sum} is total current and n is number of parallel units.

Note: Output voltage must be higher than 30% of maximum output voltage when Current Share function properly.

All specifications are subject to change without notice. Please visit our website for the most up to date specifications.

● **4000W in 2U**

Model	SP800VDC3000W	SP20VDC4000W	SP40VDC4000W	SP75VDC4000W	SP120VDC4000W
Input Voltage	208~240VAC (190~265VAC range), Installation category II				
Input Frequency	50/60Hz (47~63Hz range)				
Power Factor	>0.99				
Input Power	3400VA(MAX)	4500VA(MAX)	4500VA(MAX)	4500VA(MAX)	4500VA(MAX)
Output Voltage Range	0~800V	0~20V	0~40V	0~75V	0~120V
Output Current Range	0~10A	0~200A	0~120A	0~60A	0~40A
Output Power Range	0~3000W	0~4000W	0~4000W	0~4000W	0~4000W
Voltage Load Regulation	40mV	15mV	15mV	15mV	15mV
Current Load Regulation	20mA	200mA	120mA	60mA	40mA
Voltage Display Resolution	1mV	0.1mV	0.1mV	0.1mV	1mV
Current Display Resolution	0.1mA	1mA	1mA	0.1mA	0.1mA
Voltage Programmable Resolution	16mV	1mV	1mV	2mV	3mV
Current Programmable Resolution	1mA	3mA	3mA	2mA	1mA
Voltage Setting Accuracy ^[1]	0.05%+200mV	0.05%+15mV	0.05%+15mV	0.05%+15mV	0.1%+15mV
Current Setting Accuracy	0.1%+20mA	0.1%+200mA	0.1%+120mA	0.1%+60mA	0.1%+40mA
Voltage Measurement Accuracy ^[1]	0.05%+200mV	0.05%+15mV	0.05%+15mV	0.05%+15mV	0.1%+15mV
Current Measurement Accuracy	0.1%+20mA	0.1%+200mA	0.1%+120mA	0.1%+60mA	0.1%+40mA
Voltage Ripple ^[2]	500mVp-p 60mVrms	40mVp-p 6mVrms	40mVp-p 6mVrms	40mVp-p 8mVrms	80mVp-p 15mVrms
Current Ripple ^[3]	25mA (Full Range) 10mA (TYP Value)	300mA (Full Range) 80mA (TYP Value)	150mA (Full Range) 20mA (TYP Value)	60mA (Full Range) 10mA (TYP Value)	60mA (Full Range) 10mA (TYP Value)
Line Regulation (Voltage)	0.01%+40mV	0.01%+8mV	0.01%+8mV	0.01%+8mV	0.02%+8mV
Line Regulation (Current)	20mA	30mA	30mA	30mA	30mA
Voltage Temperature Coefficient ^[4]	100ppm/°C	100ppm/°C	100ppm/°C	100ppm/°C	100ppm/°C
Current Temperature Coefficient ^[4]	150ppm/°C	150ppm/°C	150ppm/°C	150ppm/°C	150ppm/°C
DVM Resolution	16mV	0.1mV	0.1mV	0.1mV	1mV
DVM Precision ^[1]	0.05%+200mV	0.05%+15mV	0.05%+15mV	0.05%+15mV	0.1%+15mV
Operating Mode	Constant voltage (CV) / Constant current (CC)				
Remote Compensation	5V MAX	4V MAX	4V MAX	5V MAX	5V MAX
Master-slave Control	Yes	Yes	Yes	Yes	Yes

Model	SP800VDC3000W	SP20VDC4000W	SP40VDC4000W	SP75VDC4000W	SP120VDC4000W
Response (Voltage Increase)	≤60ms	≤15ms	≤15ms	≤15ms	≤20ms
Response (Voltage Drop)	≤1200ms (no load) ≤75ms (full load)	≤300ms (no load) ≤10ms (full load)	≤350ms (no load) ≤10ms (full load)	≤450ms (no load) ≤20ms (full load)	≤350ms (no load) ≤18ms (full load)
Load Transient Recovery Time ^[5]	≤3ms	≤2ms	≤2ms	≤2ms	≤2ms
Command Response Time	50ms				
Series Capability ^[6]	Not Recommended	Up to 10 units	Up to 10 units	Up to 10 units	Up to 10 units
Parallel Capability	Up to 10 units	Up to 10 units	Up to 10 units	Up to 10 units	Up to 10 units
Current Sharing ^[7]	250V	5V	12V	20V	30V
Efficiency (full load)	91%	90%	91%	91%	92%
Protection Function	OVP/OCP/OTP/OPP/SCP				
Input Fuse	30A, 125VAC/250 VAC, fast-acting type	40A, 125VAC/250 VAC, fast-acting type	40A, 125VAC/250 VAC, fast-acting type	40A, 125VAC/250 VAC, fast-acting type	40A, 125VAC/250 VAC, fast-acting type
Net Weight	14.7kg	14.7kg	14.7kg	13.2kg	13.2kg
Accessories Weight	1.0kg	1.0kg	1.0kg	1.0kg	1.0kg
Dimensions(WxHxD)	483.0x87.0x581.0 mm	483.0x87.0x626.0 mm		483.0x87.0x581.0 mm	
Communication Modes	1. RS232/RS485/USB/LAN; 2. RS232/RS485/USB/LAN/GPIB				
Operating Environment	Temperature 0~40°C, Relative Humidity 10%~90%(no condensation); Pollution degree 2, Installation category II, Indoor use.				
Cooling Mode	Forced air-cooling				
Altitude	2000m				

[1] %output+offset, when output voltage less than 5V, offset voltage is 30mV.

[2] Vp-p@20MHz, Vrms@1.25MHz.

[3] Arms@1.25MHz, the TYP Value is measured at the rated output voltage with 100% resistive load, and the measured value at full range of output voltage with 100% resistive load is less than the Full Range value.

[4] 0~40°C.

[5] Time for output voltage to recover within 0.5% of its rated output for a load change from 10% to 90% of its rated output current. Voltage set point from 10% to 90% of rated output.

[6] The communication must insulated users from output when using remote control and the output voltage exceeds 800VDC.

[7] Current Share error $I_e < (I_{av} \cdot 2.5\% + 1) A$, $I_{av} = I_{sum} / n$, where I_{av} is average current, I_{sum} is total current and n is number of parallel units.

Note: Output voltage must be higher than 30% of maximum output voltage when Current Share function properly.

All specifications are subject to change without notice. Please visit our website for the most up to date specifications.

● **4000W in 2U**

Model	SP150VDC4000W	SP200VDC4000W	SP400VDC4000W	SP600VDC4000W	SP800VDC4000W
Input Voltage	208~240VAC (190~265VAC range), Installation category II				
Input Frequency	50/60Hz (47~63Hz range)				
Power Factor	>0.98				
Input Power	4500VA(MAX)	4500VA(MAX)	4500VA(MAX)	4500VA(MAX)	4500VA(MAX)
Output Voltage Range	0~150V	0~200V	0~400V	0~600V	0~800V
Output Current Range	0~30A	0~24A	0~15A	0~10A	0~7.5A
Output Power Range	0~4000W	0~4000W	0~4000W	0~4000W	0~4000W
Voltage Load Regulation	15mV	15mV	15mV	30mV	40mV
Current Load Regulation	30mA	24mA	15mA	10mA	20mA
Voltage Display Resolution	1mV	1mV	1mV	1mV	1mV
Current Display Resolution	0.1mA	0.1mA	0.1mA	0.1mA	0.1mA
Voltage Programmable Resolution	3mV	4mV	8mV	12mV	16mV
Current Programmable Resolution	1mA	1mA	1mA	1mA	1mA
Voltage Setting Accuracy ^[1]	0.1%+15mV	0.1%+15mV	0.05%+100mV	0.05%+150mV	0.05%+200mV
Current Setting Accuracy	0.1%+30mA	0.1%+24mA	0.1%+24mA	0.1%+10mA	0.1%+10mA
Voltage Measurement Accuracy ^[1]	0.1%+15mV	0.1%+15mV	0.05%+100mV	0.05%+150mV	0.05%+200mV
Current Measurement Accuracy	0.1%+30mA	0.1%+24mA	0.1%+24mA	0.1%+10mA	0.1%+10mA
Voltage Ripple ^[2]	80mVp-p 15mVrms	150mVp-p 30mVrms	350mVp-p 40mVrms	350mVp-p 40mVrms	500mVp-p 60mVrms
Current Ripple ^[3]	60mA (Full Range) 10mA (TYP Value)	50mA (Full Range) 20mA (TYP Value)	25mA (Full Range) 10mA (TYP Value)	25mA (Full Range) 10mA (TYP Value)	25mA (Full Range) 10mA (TYP Value)
Line Regulation (Voltage)	0.02%+8mV	0.02%+8mV	0.01%+20mV	0.01%+30mV	0.01%+40mV
Line Regulation (Current)	30mA	30mA	24mA	15mA	20mA
Voltage Temperature Coefficient ^[4]	100ppm/°C	100ppm/°C	100ppm/°C	100ppm/°C	100ppm/°C
Current Temperature Coefficient ^[4]	150ppm/°C	150ppm/°C	150ppm/°C	150ppm/°C	150ppm/°C
DVM Resolution	1mV	1mV	8mV	12mV	12mV
DVM Precision ^[1]	0.1%+15mV	0.1%+15mV	0.05%+100mV	0.05%+150mV	0.05%+200mV
Operating Mode	Constant voltage (CV) / Constant current (CC)				
Remote Compensation	5V MAX	5V MAX	5V MAX	5V MAX	5V MAX
Master-slave Control	Yes	Yes	Yes	Yes	Yes

Model	SP150VDC4000W	SP200VDC4000W	SP400VDC4000W	SP600VDC4000W	SP800VDC4000W
Response (Voltage Increase)	≤30ms	≤30ms	≤60ms	≤60ms	≤60ms
Response (Voltage Drop)	≤500ms (no load) ≤20ms (full load)	≤500ms (no load) ≤20ms (full load)	≤1200ms (no load) ≤60ms (full load)	≤1200ms (no load) ≤60ms (full load)	≤1200ms (no load) ≤60ms (full load)
Load Transient Recovery Time ^[5]	≤2.5ms	≤3ms	≤3ms	≤3ms	≤3ms
Command Response Time	50ms				
Series Capability ^[6]	Up to 8 units	Up to 6 units	Up to 3 units	Up to 2 units	Not Recommended
Parallel Capability	Up to 10 units	Up to 10 units	Up to 10 units	Up to 10 units	Up to 10 units
Current Sharing ^[7]	40V	50V	120V	200V	250V
Efficiency (full load)	93%	92%	92%	92%	92%
Protection Function	OVP/OCP/OTP/OPP/SCP				
Input Fuse	40A, 125VAC/250 VAC, fast-acting type	40A, 125VAC/250 VAC, fast-acting type	40A, 125VAC/250 VAC, fast-acting type	40A, 125VAC/250 VAC, fast-acting type	40A, 125VAC/250 VAC, fast-acting type
Net Weight	13.2kg	13.2kg	14.7kg	14.7kg	14.7kg
Accessories Weight	1.0kg	1.0kg	1.0kg	1.0kg	1.0kg
Dimensions(WxHxD)	483.0x87.0x581.0 mm				
Communication Modes	1. RS232/RS485/USB/LAN; 2. RS232/RS485/USB/LAN/GPIB				
Operating Environment	Temperature 0~40°C, Relative Humidity 10%~90%(no condensation); Pollution degree 2, Installation category II, Indoor use.				
Cooling Mode	Forced air-cooling				
Altitude	2000m				

[1] %output+offset, when output voltage less than 5V, offset voltage is 30mV.

[2] Vp-p@20MHz, Vrms@1.25MHz.

[3] Arms@1.25MHz, the TYP Value is measured at the rated output voltage with 100% resistive load, and the measured value at full range of output voltage with 100% resistive load is less than the Full Range value.

[4] 0~40°C.

[5] Time for output voltage to recover within 0.5% of its rated output for a load change from 10% to 90% of its rated output current. Voltage set point from 10% to 90% of rated output.

[6] The communication must insulated users from output when using remote control and the output voltage exceeds 800VDC.

[7] Current Share error $I_e < (I_{av} \cdot 2.5\% + 1) A$, $I_{av} = I_{sum}/n$, where I_{av} is average current, I_{sum} is total current and n is number of parallel units.

Note: Output voltage must be higher than 30% of maximum output voltage when Current Share function properly.

All specifications are subject to change without notice. Please visit our website for the most up to date specifications.

Appendix B Web Server

1. Connection Mode

This series power supplies including Web Server, offer both local operation and remote operation.

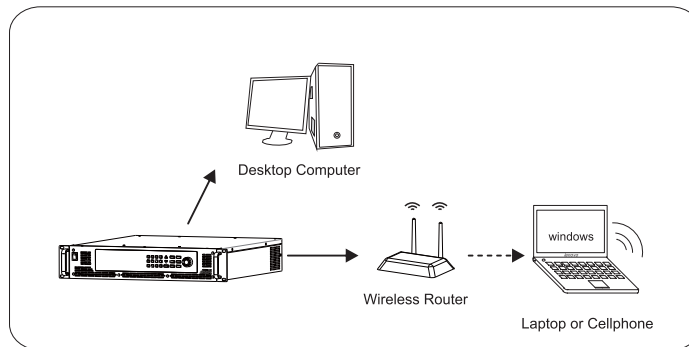

The connection above is for local operation, the IP address of the power supply and computer must be set in the same segment. It is possible to control the power supply from a laptop or a cellphone using the wireless router.

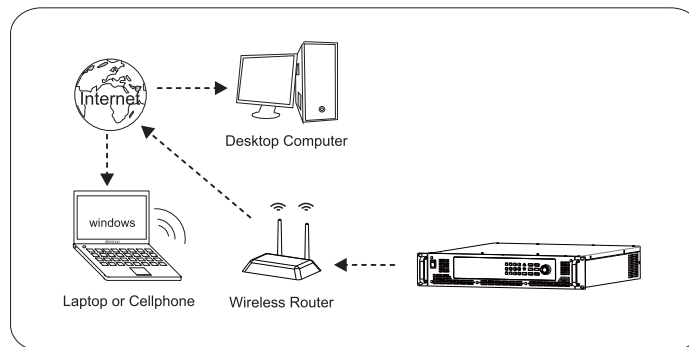

The connection above is for remote operation, the wireless router is connected to the internet.

2. WebServer

2.1 Login Menu

On the computer, open up the web browser, copy down the IP ADDR that you assigned and type that address in the URL bar of your browser. If correctly configured, the following screen will be shown:

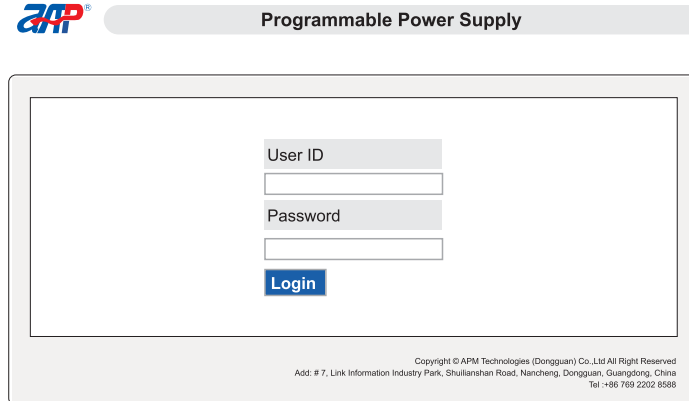

A password is required to login and access any of the menu items on the page. The User ID is “Admin”, and the default admin password is “123456”.

2.2 Home Menu

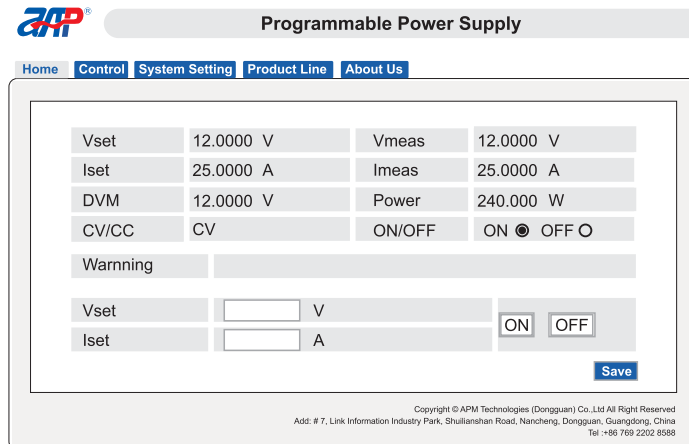

Home menu allows the user to set up the voltage, current, and output state of the power supply. The voltage measured value, current measured value and operating mode of the power supply will be shown on the page as well.

2.3 Control Menu

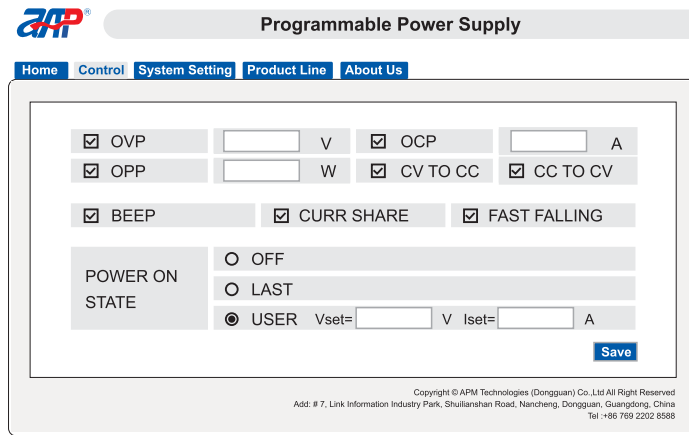

APM Programmable Power Supply

[Home](#) [Control](#) [System Setting](#) [Product Line](#) [About Us](#)

<input checked="" type="checkbox"/> OVP	<input type="text"/>	V	<input checked="" type="checkbox"/> OCP	<input type="text"/>	A
<input checked="" type="checkbox"/> OPP	<input type="text"/>	W	<input checked="" type="checkbox"/> CV TO CC	<input checked="" type="checkbox"/> CC TO CV	
<input checked="" type="checkbox"/> BEEP	<input checked="" type="checkbox"/> CURR SHARE	<input checked="" type="checkbox"/> FAST FALLING			
POWER ON STATE	<input type="radio"/> OFF				
	<input type="radio"/> LAST				
	<input checked="" type="radio"/> USER	Vset= <input type="text"/>	V	Iset= <input type="text"/>	A

[Save](#)

Copyright © APM Technologies (Dongguan) Co., Ltd All Right Reserved
 Add: # 7, Link Information Industry Park, Shuilianshan Road, Nancheng, Dongguan, Guangdong, China
 Tel: +86 769 2202 8588

Control menu allows the user to configure the following parameters: OVP setting, OCP setting, OPP setting, CV TO CC protection, CC TO CV protection, BEEP setting, CURR SHARE setting, FAST FALLING setting and POWER ON STATE setting.

2.4 System Setting Menu

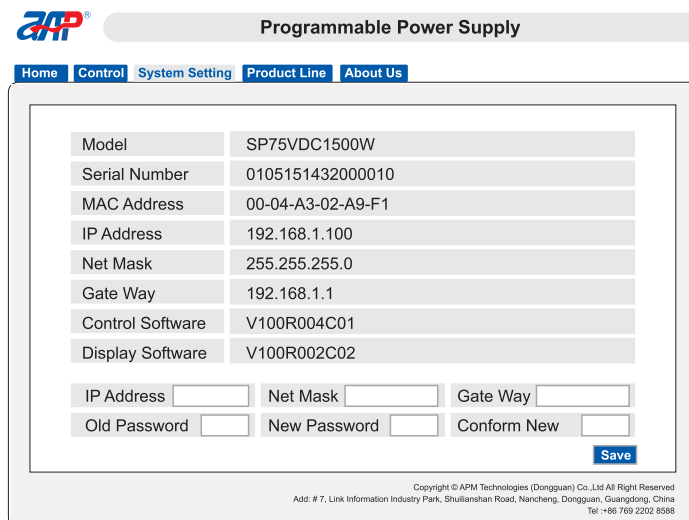

APM Programmable Power Supply

[Home](#) [Control](#) [System Setting](#) [Product Line](#) [About Us](#)

Model	SP75VDC1500W				
Serial Number	0105151432000010				
MAC Address	00-04-A3-02-A9-F1				
IP Address	192.168.1.100				
Net Mask	255.255.255.0				
Gate Way	192.168.1.1				
Control Software	V100R004C01				
Display Software	V100R002C02				

IP Address <input type="text"/>	Net Mask <input type="text"/>	Gate Way <input type="text"/>
Old Password <input type="text"/>	New Password <input type="text"/>	Conform New <input type="text"/>

[Save](#)

Copyright © APM Technologies (Dongguan) Co., Ltd All Right Reserved
 Add: # 7, Link Information Industry Park, Shuilianshan Road, Nancheng, Dongguan, Guangdong, China
 Tel: +86 769 2202 8588

System Setting menu shows the information of the power supply. The user can change LAN communication parameter and the password on this page.

2.5 Product Line Menu

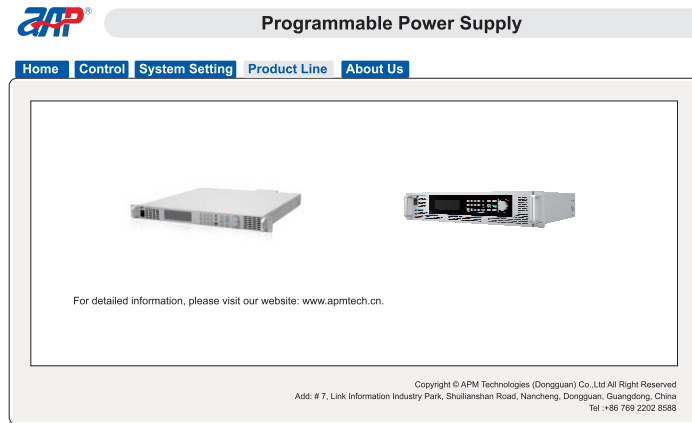

Product Line menu shows the PPS product line of APM.

2.6 About Us Menu



About Us menu provides the profile of APM.

Appendix C Warranty

Thank you for purchasing the Programmable DC Power Supply of APM Technologies (referred to hereafter as “APM”). In order for you to use our products properly, APM provides you with the standard warranty service as stipulated below. Please read the following instructions carefully.

This warranty card is applicable to the Programmable DC Power Supply of APM.

All quality warranties and services offered by your distributors are not subject to or covered by this warranty card. Our company bears no responsibility for honoring any commitment or warranty in the aspect for quality warranty or services made by the distributors.

Warranty Period

1. The warranty period of APM Programmable DC Power Supply is 2 (two) years, or refer to relevant Distributor Agreement terms.
2. The warranty period will not be extended or recalculated after a product or component replacement; repaired or replaced products are covered for the remainder of the original warranty period and subject to the conditions outlined in the original warranty.

Warranty Terms

1. In case of product malfunction within the warranty period, please send both the scanned copy of warranty card and purchasing invoice to the APM Customer Service by email. APM will provide you services for maintenance and replacement of defected product or components according to the actual conditions. Whatever method we may adopt, APM always strives to provide you with the highest standard and utmost professional after-sales services.
2. In case of product replacement, all replaced or exchanged parts which are removed under this warranty will become the property of APM. Please return the replaced product and components to the original place of purchase for APM to collect the replaced items in a certain period of time.

Liability Waiver

APM reserves the rights to refuse product warranty service under the following circumstances:

1. The product is out of warranty period.
2. Inability to provide the purchasing invoice issued either by the product distributor or the installer besides of unable to determine the product manufacturer as APM.
3. APM logo or product label is missing or not readable.
4. Product is without an anti-dismantle label or the anti-dismantle label is damaged.
5. Accessories included with each product are not in the product warranty scope
6. Defects or damages caused by or resulting from inadequate or improper repairs carried out by any person, entity or service facility which is not authorized by APM to perform warranty services on its behalf.
7. Defects or damages caused by or resulting from failure to comply with the operating instructions and contents specified in the related product manuals.
8. Defects or damages due to operation in very harsh environment that is beyond the limitations specified in this product manual.
9. Defects or damages due to the use of non-standard parts or software or parts which are not developed or manufactured by APM.
10. Defects or damages caused by or resulting from force majeure (including but not limited to lightning, immersion in liquid, etc.).
11. Defects or damages caused by or resulting from accidents or negligent use (including but not limited to transportation, storage, connection to incompatible voltage, improper operation, etc.).
12. Cosmetics defects or damages which won't affect normal operation of the product.

For the malfunction caused by above-mentioned circumstances, APM or its authorized service facility based on its own judgment is willing to provide a paid service in respond to our customer's request.

Disclaimer

1. APM will bear no responsibility for the compensation of direct or consequential functional malfunction caused by or resulting from product failure. APM will not be responsible for the data loss caused by or resulting from improper operation or due to non-product quality problem. The user should appropriately back up the data by themselves. Nor will APM be responsible for the personal injury or property losses caused by or resulting from non-product quality problem. If in any situation APM puts forward or expresses the warranty commitments conflicting with the above clauses, it should be subject to the later one.
2. In order to uphold your warranty rights, please call or mail APM Customer Service to register your product and to put warranty coverage in force.
3. Only APM has the rights to revise the conditions of the warranty given; any trader, distributor or installer has no rights to make any modification to the warranty provided by APM, or represent APM to express any opinion and behavior; APM reserves the final interpretation rights.
4. Should any malfunction of product occurs, please contact your installer, distributor or dealer timely so as for us to provide you with corresponding and appropriate services.
5. If technicians of APM provide you an on-site service, please show the warranty card which should be filled out by the visiting technicians.

Remark

1. Please retain the schedule and your purchase invoice as the proofs for warranty.
2. Please show the schedule each time prior to beginning of work for the maintenance personnel to fill out.
3. The schedule should be properly kept within product warranty period as APM won't issue any replacement schedule after the loss of the original one.

Schedule

Product Information		
Distributor	Company Name	
	Contact Person	
	Phone Code	
	Address	
User's Information		
User	Name	
	Phone Code	
	Address	
	Fax	
	E-mail	
Product Malfunction Information		
Model		
Serial No.		
Warranty Period		
Date of Malfunction	Signature	Malfunction Description & Solutions

Please stick the product
Serial number here.



目录

前言	98
安全注意事项	99
1 关于本手册	100
1.1 目的	100
1.2 目标群体	100
1.3 手册使用及法律事项声明	100
2 开包检查	101
2.1 交付范围	101
2.2 检查运输损坏	102
3 产品概述及使用简介	102
3.1 产品概述	102
3.2 产品特点	102
3.3 使用说明	103
3.4 使用环境	103
3.5 保存	103
3.6 维护与清洁	103
3.7 电源电压	103
3.8 保险丝	104
3.9 预热时间	104
3.10 关机	104
3.11 使用注意事项	104
3.12 开机程序	104

4 面板操作	106
4.1 前面板说明	106
4.1.1 功能按键说明	106
4.1.2 多功能按键说明	107
4.1.3 前面板操作介绍	107
4.1.4 前面板操作	107
4.1.5 存取操作	108
4.1.6 菜单操作	108
4.1.7 SYSTEM SETTING/系统设置	109
4.1.8 OUTPUT SETTING/输出设置	116
4.1.9 INFORMATION/电源信息	118
4.1.10 PROTECTION/保护设置	118
4.1.11 SERIES/PARALLEL/串并联设置	122
4.1.12 TIMER CONTROL/定时设置	125
4.1.13 SPECIAL TEST FUNC/特殊测试功能	126
4.1.14 ADDITIONAL FUNCTIONS/客制新增功能	131
4.2 后面板说明	132
4.2.1 输入连接	133
4.2.2 输出连接	135
4.2.3 远端补偿	136
4.2.4 DVM	137
5 典型应用	138
5.1 外部设定	138
5.2 计数器功能	138
5.3 超低压模式功能	139
5.4 主从并机设定	140
5.5 List波形编辑功能	141

6 SCPI通信协议	142
6.1 相关指令描述	143
6.1.1 IEEE-488.2公用指令集	143
6.1.2 全天科技可编程直流电源所指定的指令	143
7 软件介绍	151
7.1 说明	151
8 常见故障及解决方案	152
9 安装	153
9.1 电源尺寸图	153
9.2 电源上架安装图	153
9.3 握把安装	154
10 回收处理	154
11 联系我们	154
附录A 技术规格	155
附录B Web Server介绍	179
附录C 质保声明	183

前言

尊敬的用户，非常感谢您使用全天自动化能源科技(东莞)有限公司研制的可编程直流电源产品，我们由衷地希望本产品可以满足您的需求。

本手册所描述的各部分内容适用于以下机型：

功率 ○ 电压 □	1U 电源					2U 电源			
	600W	1000W	1200W	1500W	1600W	1000W	2000W	3000W	4000W
20VDC	-	-	-	-	-	200A ^[1]	200A	200A	200A
32VDC	-	-	-	-	-	-	-	120A	-
40VDC	-	-	-	-	-	120A ^[1]	120A	120A	120A
60VDC	-	-	-	-	-	-	-	-	-
75VDC	-	-	-	-	-	50A ^[1]	50A	50A	60A
80VDC	-	-	-	-	-	-	60A	60A	-
120VDC	-	-	-	-	-	40A ^[1]	40A	40A	40A
150VDC	10A ^[2]	10A ^[2]	10A ^[2]	10A ^[2]	-	30A ^[1]	30A	30A	30A
200VDC	8A ^[2]	8A ^[2]	8A ^[2]	8A ^[2]	-	24A ^[1]	24A	24A	24A
400VDC	10A ^[2]	10A ^[2]	10A ^[2]	10A ^[2]	-	15A ^{[1][2]}	15A ^[2]	15A ^[2]	15A ^[2]
600VDC	8A ^[2]	8A ^[2]	8A ^[2]	8A ^[2]	-	10A ^{[1][2]}	10A ^[2]	10A ^[2]	10A ^[2]
800VDC	5A ^[2]	5A ^[2]	5A ^[2]	5A ^[2]	-	7.5A ^{[1][2]}	7.5A ^[2]	7.5A ^[2]	7.5A ^[2]

选型指导

SP 功率

└──────────┘

电压

例如 SP200VDC1500W

注: SP 是 Switching Power 的缩写。

^[1] **选型指导**

SPS 功率

└──────────┘

电压

^[2] 该型号电源的DVM与外部控制功能为选配项。

2017年6月发行，版本 D

正式发行第四个中英文合辑版本，删减或更新部分机型参数。

安全注意事项



警告!

此符号警示用户在操作设备时应完全了解该注意事项，避免在使用时给使用者带来危险。



注意!

此符号提醒用户在操作设备时要留意该注意事项，避免在使用时没有及时察觉而对使用者造成伤害。



说明

此符号表示用户在使用前请仔细阅读说明书，避免对使用者以及设备造成损害。



此符号表示高压危险!



此符号表示高温，请勿任意触碰设备，以防烫伤。



此符号表示接地，在操作此设备前，标示为此符号的端子必须接地，以防止电击。

1 关于本手册

1.1 目的

尊敬的用户，感谢您选用全天自动化能源科技(东莞)有限公司(以下简称“全天科技”)研发的新一代可编程直流电源产品。我们希望本产品能满足您的需求，同时希望您能对产品的性能和功能提出更多的建议/意见，我们将持续改进，不断提升我们的产品质量和服务水平。

本手册目的在于向读者提供详细产品信息以及安装操作维护说明。

1.2 目标群体

本手册适用于对可编程直流电源进行安装、操作、维护的专业技术人员及日常操作中的用户。读者需具备一定的电气及机械专业知识，熟悉基本的电气、机械原理图。

1.3 手册使用及法律事项声明

本手册使用的任何内容(包括但不限于图片、标识、符号、数据等)均为全天科技所有，未经授权，不得转载。

手册内容将不断更新、修正，但难免存在与实物稍有不符或错误的情况。请以所购买的产品实物为准，并通过 www.apmtech.cn 下载或销售渠道索取最新版本的手册资料。

禁止以任何方式将本公司开发的硬件或软件中的部分或者全部资料用于商业目的。禁止对本公司开发的软件进行反编译、解密或其他破坏原始程序设计的操作。

2 开包检查

2.1 交付范围

物件	说明	数量	备注
A	可编程直流电源	1 台	客户选定型号
B	握把[1]	2 个	标配
C	输入防护罩[1]	1 个	标配
D	固定螺丝组[1]	8 颗	固定握把与防护罩
E	电源线(全电压范围适用)	1 根	标配
F	电源线(仅176~265VAC范围适用)[2]	1 根	选配
G	RS-232 通讯线缆	1 根	标配
H	LAN 通讯线缆(标准568A-568B)	1 根	标配
	LAN 通讯线缆(标准568A-568A)	1 根	标配
I	USB 通讯线缆	1 根	标配
J	GPIB 通讯线缆	1 根	选配
K	均流线缆	1 根	并联均流时连接
L	系统总线通讯线缆	1 根	主从通讯时连接
M	快速指南	1 份	标配

[1] 仅2U电源以附件形式提供；

[2] 此线缆仅适用于1U电源，客户选配此线缆时，电源的输入已经做出对应调整，此电源也仅适用于176~265VAC的输入，如需调整电源至全范围输入，请联系代理商。

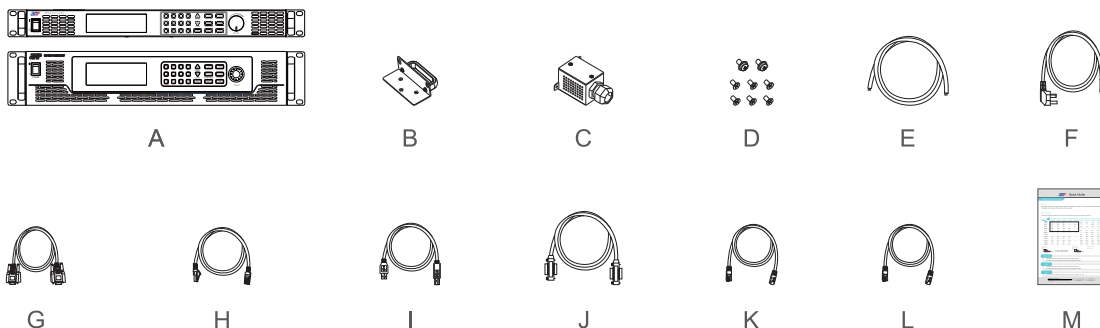

2.2 检查运输损坏

全天科技的所有产品在出厂前都经过了严格的检测，但在运输过程中难免出现损坏情况。一旦到货，请立即全面检查，如发现任何可能导致机器损坏的包装损坏，请立即通知运输公司或与我公司联系，并请您提供损坏处照片，我们将提供最佳的服务与支持。

3 产品概述与使用简介

3.1 产品概述

此系列产品是一款单组电源输出的可编程直流电源，精密型。使用16bit D/A，24bit A/D采样电路，电压分辨率为1.5mV，电流分辨率为1mA。

提供主从串/并联模式扩展功率输出，让你在电路应用与测试上更加方便，灵活。

面板设置使得用户可以方便自如的设置输出参数，亦可以预览本机的设置。

具有过电压、过电流、过温以及过功率等保护功能。

后面板包括控制与监控的必要连接器，可通过模拟信号或者内置的远程通信接口来操作电源。

3.2 产品特点

- 宽电压输入范围
- 高功率密度
- 主/从并联&串联操作模式可达10台
- 精准的电压及电流量测
- 高速可编程界面
- 编码旋钮、多功能键盘操作
- CV与CC工作模式的自由切换
- 电压渐升/降功能
- 具有可编程及多个步骤设定电压/电流
- 过电压、限电流、过功率及过温保护功能
- 标配USB/LAN/RS485/RS232通信接口

- 使用标准的SCPI通信协议
- 标准的模拟外部接口，远程输出
- 远程感测(Remote Sense)线压降补偿
- DVM独立测量功能

3.3 使用说明

本机为精密仪器，请在使用前仔细阅读此说明书，且为保证其精度，建议每年定期校验。

3.4 使用环境

1. 请在温度为0~40℃，相对湿度为10%~90%的实验室或测试车间使用此精密电源。
2. 请勿在高温条件下长时间使用电源，如果电源的机壳温度超过40℃，请先暂停使用，待其温度下降至正常温度后再使用，避免温度过高影响其正常使用。
3. 请勿在高温条件下长时间使用电源，且部分机种在40~50℃的环境中请降额运行，长时间过温运行会触发过温保护，请采取措施，待其温度下降至正常温度后再使用，避免温度过高影响其正常使用。
4. 电源的冷却方式为强制风冷，请勿遮挡电源背后的通风口，保证电源前后面板与墙壁或物体有20cm以上的间距。
5. 请勿在含有大量粉尘、震动剧烈、日光直射或有腐蚀性气体的环境下使用电源。

3.5 保存

请将本机储存在-20℃~70℃，0%~90%RH无结露的环境中，若长时间不使用，请以原包装或其他类似的包装保存于干燥阴凉处。

3.6 维护与清洁

清洁前，必须移除机器的输入电源线，可用毛刷或者纱布轻轻地擦去机器外部的灰尘。当外壳的污渍用毛刷等无法清除时，可用挥发性液体(如去渍油)擦拭机壳，不可用腐蚀性液体以免破坏机壳。前面板VFD可用纱布沾肥皂水或软性清洁剂清洁。机器内部的清洁必须使用低压力空气枪将机器内部的灰尘清除，最好送给经销商代为清洁。

3.7 电源电压

在接上电源之前，请务必确认电源的输入电压满足其要求，且开关处于OFF状态。



- 断开输入电源线前不可以断开保护地线，接通输入电源前要先接通保护地线。

3.8 保险丝

安装于本机内部的电源保险丝，属于硬件多重保护设计，正常使用时极不易断开，若有熔断现象代表机内其他故障而导致提前保护，建议回厂检修。



- 不建议使用者自行拆卸机壳更换保险丝，以免误装导致危险！

3.9 预热时间

本机的所有功能在电源开启时同时动作，但为能达到规格内的准确度，请预热约30分钟。

3.10 关机

当不再需要使用本机或者是在使用中需离开时，请务必将面板开关切在OFF处，之后内部风扇仍会继续运转数秒来进行内部电容的放电，待放电完成后，本机会自动关机。

3.11 使用注意事项

1. 接通电源前，请确认各直流电源的开关处于OFF状态，且输出端子已做必要防护。
2. 直流电源输出前请检查各设定值是否符合输出要求。

3.12 开机程序

接上电源并开启前面板上的电源开关，直流电源将做一系列的自我检测。

开机后首先显示公司名称：



APM Technologies

1s后，进入自检程序：

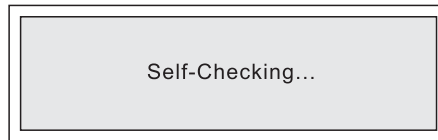

同时，直流电源将进行存储器以及通讯等自检程序。

完成自检后，自动跳转到主界面：

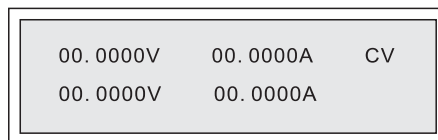

第一行显示为电源的电压回读值，电流回读值以及电源的工作模式，第二行显示电压的设定值以及电流的限定值。

按下组合键 **Shift** + **Display** 进入如下界面：

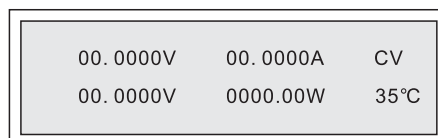

第一行显示电源的电压回读值、电流回读值以及电源的工作模式，第二行显示电源的DVM值，输出功率以及机内温度。按下 **Display** 返回主界面。

4 面板操作

4.1 前面板说明

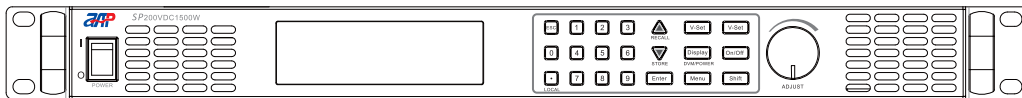

1U电源前面板

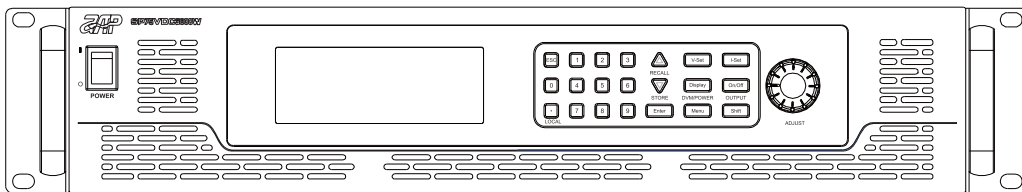

2U电源前面板

4.1.1 功能按键说明

按键	说明
0~9	数字键
.	小数点
ESC	退出键
▲	上移动键，在菜单操作中选择菜单或者增大各设定值
▼	下移动键，在菜单操作中选择菜单或者减小各设定值
Enter	确认键
V-set	设定电源输出电压值
I-set	设定电源输出限流值
Display	按下此键可快速回到主界面
On/Off	控制电源的输出开/关
Menu	菜单键
Shift	与多功能键一起使用实现多种功能

4.1.2 多功能按键说明

按键	说明
LOCAL	面板操作
RECALL	从内存中调用存储的电源设定值
STORE	存储电源的当前设定到存储位置
DVM/POWER	显示DVM值与功率值

4.1.3 前面板操作介绍



说明

- 若使用者在关机之前，未储存指定操作方式，下次重新启动时，操作方式会是默认的面板操作模式。
1. 前面板上的ON/OFF键可以用来开关电源的输出；
 2. 电源操作模式包括面板操作模式，远程操作模式以及外部控制模式，前两种操作模式可以通过PC机控制切换，且改变操作模式，也不会影响电源的输出参数；
 3. 在电源上电后，电源自动为面板操作模式，此时可以使用所有的按键；
 4. 当电源为远程操作模式时将会被锁定，此时面板按键不起作用。

4.1.4 前面板操作

4.1.4.1 电压设定

输出电压(CV MODE，注意电流设定需大于负载电流以维持输出处于CV模式，否则输出电压不会等于设定的电压)，有以下两种设定方式：

方式一(利用按键)

1. **V-set** + **0** ~ **9** + **Enter** 键设定电压值；
2. 按 **On/Off** 键输出设定的电压。

方式二(利用旋钮)

1. 按下 **V-set** 键；
2. 通过按动旋钮将游标移到不同的位数上，然后转动旋钮，会以此位数为设定值增加或减小的最小单位，并按下 **Enter** 键确认；
3. 按 **On/Off** 键输出设定的电压。直流电源正在输出时也可以按此两种方法设定。

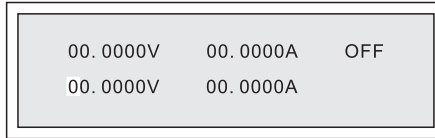

4.1.4.2 电流设定

设定电流 (CC MODE, 注意电压设定需大于负载电压以维持输出处于CC模式, 否则输出电流将不等于设定的电流)的方式如下, 按下 **I-set** 键, 其余设定方式与电压设定相同。

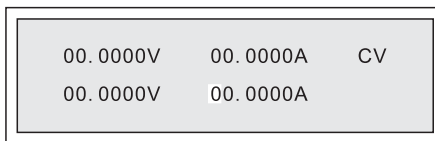

4.1.5 存取操作

电源可以把一些常用的参数, 如电压设定值、电流设定值等, 分别保存在50组非易失性的内存中, 供用户快速地调出使用。用 **Shift + ▾ + 0 ~ 9 + Enter** 键, 把常用的参数存储在指定的存储区域, 也可以用 **Shift + ▲ + 0 ~ 9 + Enter** 键从指定的存储区域取出参数使用。

4.1.6 菜单操作

按下 **Menu** 进入菜单, VFD上显示出可供选择的菜单选项, 可通过 **▲ ▽** 按键来选择要进入的目标菜单, 按下 **Enter** 键, 将会进入游标所在位置的菜单选项, 按下 **Esc** 键返回上一级菜单。

一级菜单有以下选项：

1. SYSTEM SETTING	系统设置	进行系统参数设定
2. OUTPUT SETTING	输出设置	进行设定输出参数
3. INFORMATION	电源信息	显示电源的软件版本号等信息
4. PROTECTIONS	保护设置	进行各项保护功能的设定
5. SERIES/PARALLEL	串/并联设置	进行串并联模式下的设定
6. TIMER CONTROL	定时控制	进行无人监控自动运行时间的设定
7. SPECIAL TEST FUNC	特殊测试功能	进行特殊功能测试的设定
8. ADDITIONAL FUNCTIONS	新增功能	进行客户定制功能扩展

功能菜单详情：

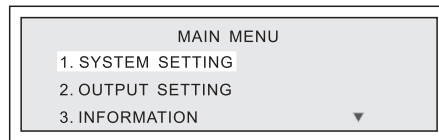

按下 ▼ 可跳至下一页：

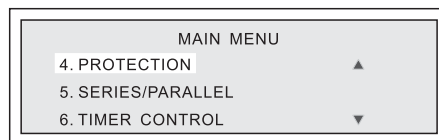

按下 ▲ 可跳至上一页，按下 ▼ 可跳至下一页：

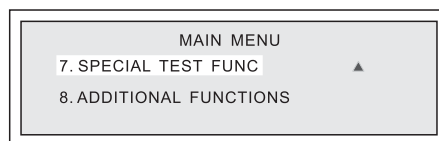

4.1.7 SYSTEM SETTING / 系统设置

按下  进入菜单，进入SYSTEM SETTING选项后，按 ▲ ▼，依次会出现以下菜单选项。

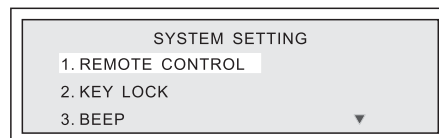

1. REMOTE CONTROL

该菜单用来设定传输接口，本机的通讯接口包括RS232/RS485/USB/LAN/GPIB。

RS232

在此界面下按下  键进入以下界面：

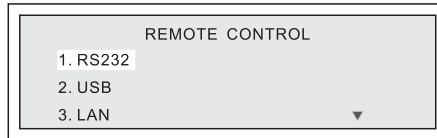

选取通讯方式进入后，可修改通讯方式下的属性，RS232属性选择界面：

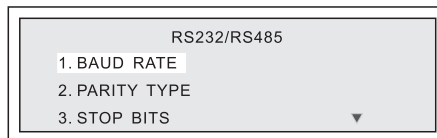

BAUD RATE波特率选择，包括9600(默认值)、19200、38400、57600；
PARITY TYPE奇偶校验位，包括None(默认值)、Odd、Even；
STOP BITS停止位，包括1(默认值)、2。

USB

光标选中USB，点击 **Enter** 键进入，用户可从该界面下获得电源的USB 通讯地址：

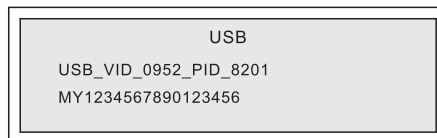

LAN

当前界面，点击 **Enter** 键进入如下界面：

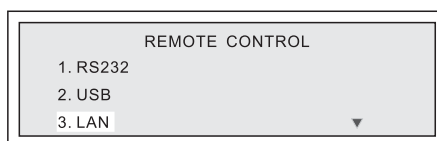

光标选中LAN，点击 **Enter** 键进入：

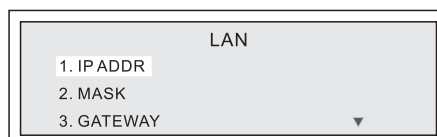

光标选中IP ADDR， 点击  键进入， 利用数字键  ~  +  完成设定；

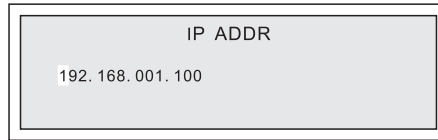

同样方式完成MASK以及GATEWAY的设定， 地址范围0~255；

点击  键进入下一页， 光标选中LISTEN PORT， 点击  键进入， 利用数字键  ~  +  键完成电源侦听端口的设定；

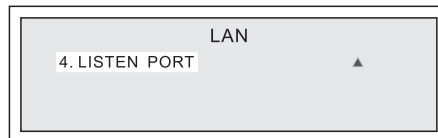

RS485

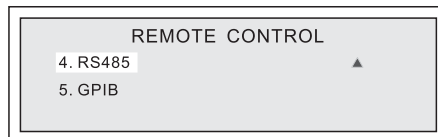

在此界面下按下  键进入RS485通讯参数设定界面：

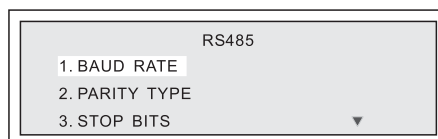

BAUD RATE 波特率， PARITY TYPE 奇偶校验位， STOP BITS 停止位等参数内容与RS232通讯方式下的参数一致。

点击  键进入下一页：

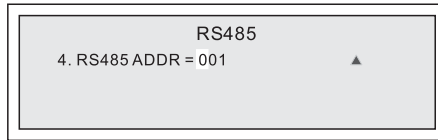

RS485通讯地址选择，包括1~254，利用 **0**~**9** + **Enter** 完成设定。

RS485通讯支持串接功能，最多可至30台，设置电源为不同的地址，需在最后一台的485A与485B之间连接120Ω的终端电阻，通讯连接方式如下图：

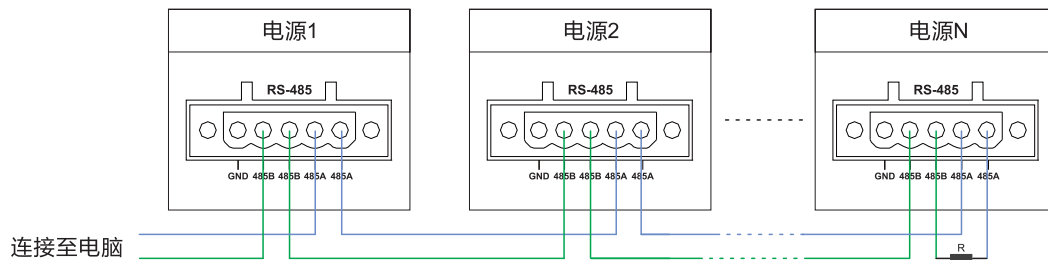

GPIB

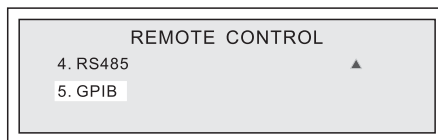

在此界面下按下 **Enter** 键进入GPIB通讯地址设定界面：

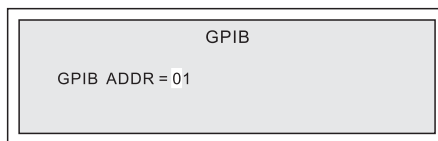

GPIB通讯地址选择，包括1~30，利用数字键 **0**~**9** + **Enter** 键完成设定。

2. KEY LOCK

该菜单设置为ON后会使得所有的按键失去作用，只有按小数点才能解除此状态。

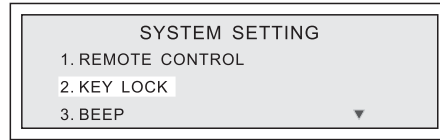

按下  键进入如下界面：

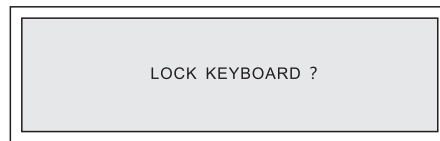

按下  键，回到主界面，且在右下角显示一把锁的标识：

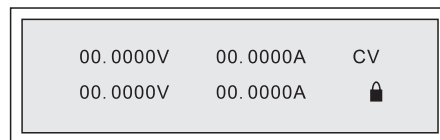

若要解锁，按下小数点键，弹出UNLOCK KEYBOARD 的界面，按下  键即可解锁。

3. BEEP

此菜单用来设定蜂鸣器开或关。

说明：1. BEEP可设置的选项有两种：ON/OFF，默认为ON；

2. 当BEEP设置为ON时，按压任一按键或者旋钮时，BEEP皆会发出声音；
3. 当BEEP设置为ON时，若系统发生保护，BEEP会发出一连续声音，以提醒使用者；
4. 当BEEP设置为OFF时，按压任一按键或者旋钮时，BEEP皆不会发出声音但在发生保护时会发出声音以提醒使用者。

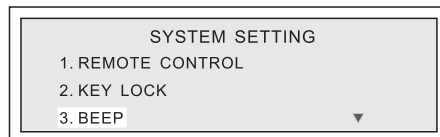

按下  键进入如下界面：



按下 Δ 或 ∇ 按键可切换光标处ON/OFF，选择后，按下 Enter 键，就可打开或关闭蜂鸣器的声音。

4. POWER ON STATE

此菜单用来设定电源开机之后的状态。

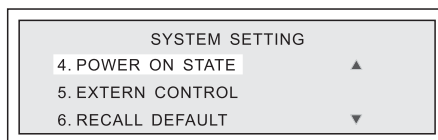

按下 Enter 键进入如下界面：

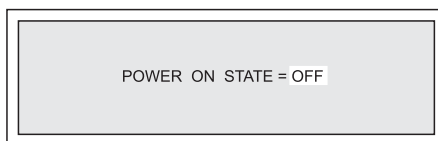

- 说明：1. POWER ON STATE 可设定的选项有3种：LAST/USER/OFF，可按 Δ ∇ 切换；
2. 当设定为LAST时，设备会记录关机前命令电压、电流以及输出状态，待使用者下次开机时，可维持前一次关机时的状态；
3. 当设定为USER时，会在POWER ON STATE设定列下方弹出一设定列，如下图所示，开机后电源按照用户的设定值输出：

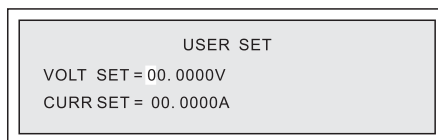

4. 当设定为OFF时，对开机输出状态不作特别定义，电压为0，电流为最大值。

注意：无论哪种设置，在电源上电之后的输出状态均为OFF，直到用户自己打开电源的输出。

5. EXTERN CONTROL

该菜单用来控制模拟量输出。

可设定外部控制为电压控制 (VOLT 0-5V)，电阻控制 RES，并且在开启外部电压/电阻控制后会在主界面的右下角显示EXV/EXR。

注: 外部控制在主从模式下不起作用。

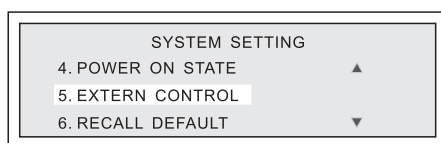

按下  键进入如下界面：

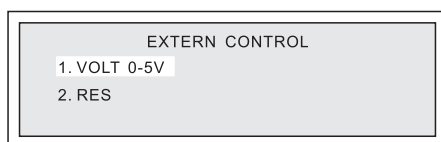

按下  键进入如下界面：

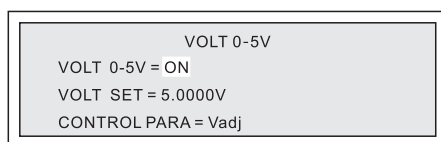

在开启外部电压控制后，按下  键，光标移动到下一行，可设定电压值，若将电压设定为 3V，即 $V_{set}=3.0000V$ ，则直流源输出类比如下图a。 $V_{adj}/I_{adj}/Both$ 意指外部电压控制直流源的电压/电流/电压与电流设定值。

图a/b以SP75VDC1500W为例。

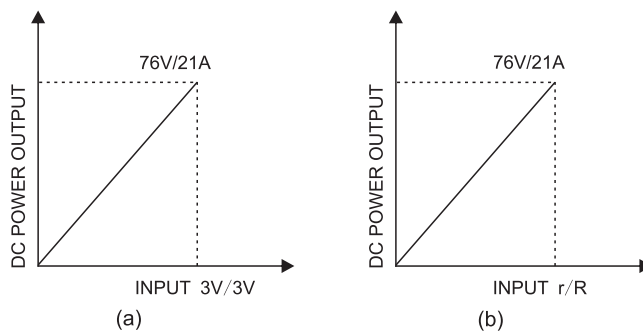

图c/d以SP75VDC3000W为例，均类比其最大电压/电流值。

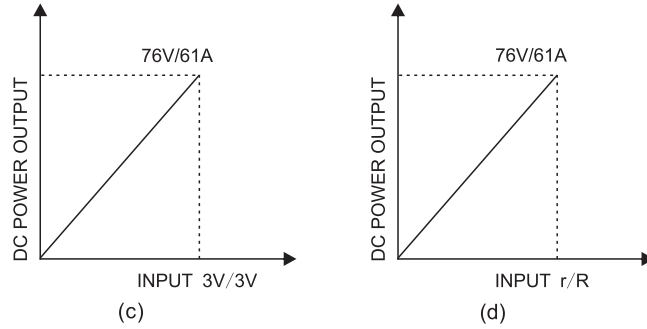

开启外部电阻控制方法同上，其中R为外接电阻值，r为分压电阻值，则直流源输出出类比如图b/d。

6. RECALL DEFAULT

此菜单用来恢复出厂设置。

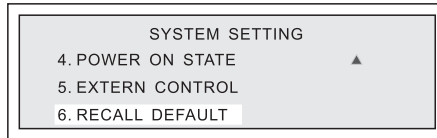

按下 **Enter** 键进入如下界面：

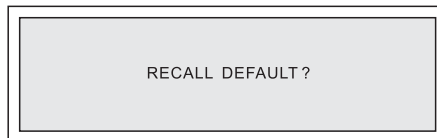

按下 **Enter** 键后，设备的各项参数设置均恢复到出厂值。

4.1.8 OUTPUT SETTING / 输出设置

按下 **Menu** 键进入菜单，进入OUTPUT SETTING选项后，按 **▲▼**，依次出现如下菜单选项。

1. VOLT LIMIT MAX, 设定电压输出最大限值，默认为最大电压值；
2. VOLT LIMIT MIN, 设定电压输出最小限值，默认为0；
3. CURR LIMIT MAX, 设定电流输出最大限值，默认为最大电流值；
4. CURR LIMIT MIN, 设定电流输出最小限值，默认为0；
5. ADVANCED FUNCTIONS, 设定开启均流功能以及超低压模式功能；

OUTPUT SETTING菜单详情：

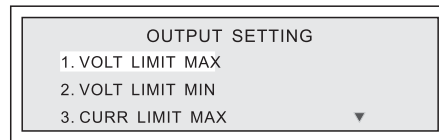

1. VOLT LIMIT MAX

按下  键进入如下界面：

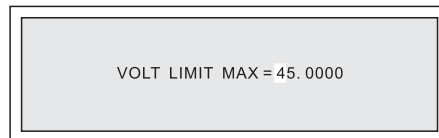

通过旋钮或者按键即可修改电压输出的最大限值。

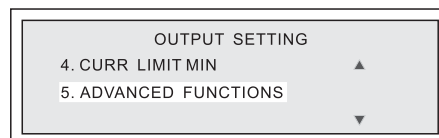

2. VOLT LIMIT MIN、3. CURR LIMIT MAX、4. CURR LIMIT MIN的设定方法同上。

5. ADVANCED FUNCTIONS

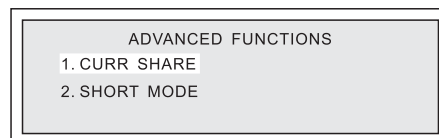

按下  键进入如下界面，包括1. CURR SHARE均流功能，2. SHORT MODE超低压模式。



在当前界面下按下  键进入以下均流功能界面，按   键，打开或关闭电流均流功能，默认为OFF。

注：均流模式下，电压输出值会稍稍高于设定值。



SHORT MODE设置为ON，当电源进入CC模式，电流回读值大于2A，且电压回读值低于0.7V时，电源进入短路模式，将关闭输出。SHORT MODE设置为OFF，电源进入超低压模式，可用于一些特殊场合，比如线缆载流能力的测试。该项默认设置为ON。

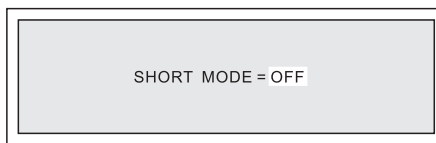

- 电源断电后会保存设置，如不需超低压模式，需用户手动进行修改设置以免烧坏待测物。

4.1.9 INFORMATION / 电源信息

按下  键进入菜单，选择INFORMATION子菜单，此界面显示电源的型号，控制程序版本号，通讯程序的版本号。

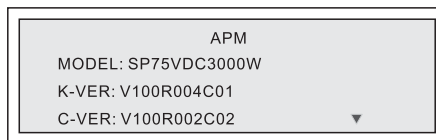

第二页为显示版本以及产品的序列号：

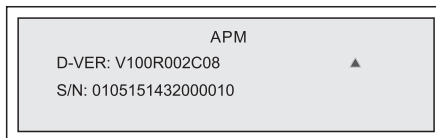



4.1.10 PROTECTION / 保护设置

按下  键进入菜单，进入PROTECTION选项后，按  键，依次会出现以下菜单选项：



1. OVP

在此界面下按下  键进入以下界面，按  键开启或关闭过压保护，确定后，光标右移，此时可设定过压保护点，通过此功能设定过电压的保护点，一旦输出电压超出此范围，则会将输出关掉，用以保护待测物。

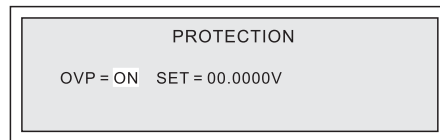

2. OCP

方法同OVP设定，通过此功能设定过电流的保护点，一旦输出电流超出此范围，则会将输出关掉，用以保护待测物。

3. OPP

方法同OVP设定，通过此功能设定过功率的保护点，一旦输出功率超出此范围，则会将输出关掉，用以保护待测物。

4. CC TO CV

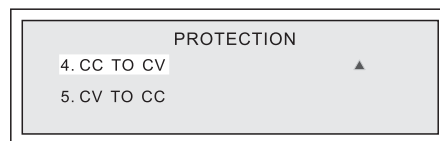

在此界面下按下  键进入以下界面，按  键开启或关闭定电流转换成定电压的保护。

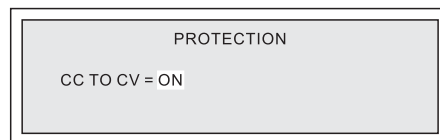

5. CV TO CC设定同CC TO CV设定，用以开启或关闭定电压转换成定电流的保护。

4.1.10.1 过电压保护功能

当测量电压大于保护电压时，过电压保护功能被启动，电源便会进入过电压保护模式 (Over Voltage Protection)，电源将自动关闭输出电压电流，并出现以下画面，按下 **Enter** 键可解除保护画面及蜂鸣器状态。

00.0000V	00.0000A	CV
00.0000V	00.0000A	OVP

4.1.10.2 过电流保护功能

当量测电流大于保护电流时，过电流保护功能被启动，电源便会进入过电流保护模式 (Over Current Protection)，电源将自动关闭输出电压电流，并出现以下画面，按下 **Enter** 键可解除保护画面及蜂鸣器状态。

00.0000V	00.0000A	CV
00.0000V	00.0000A	OCP

4.1.10.3 过功率保护功能

当量测功率大于保护功率时，过功率保护功能被启动，电源便会进入过功率保护模式 (Over Power Protection)，电源将自动关闭输出电压电流，并出现以下画面，按下 **Enter** 键可解除保护画面及蜂鸣器状态。

00.0000V	00.0000A	CV
00.0000V	00.0000A	OPP

4.1.10.4 定电压保护功能(CV TO CC)

当定电压保护功能被启动且量测进入定电流模式 (CC)，电源便会进入定电压保护模式 (CV TO CC Protection)，电源将自动关闭输出电压电流，并出现如下画面，按下 **Enter** 键可解除保护画面及蜂鸣器状态。

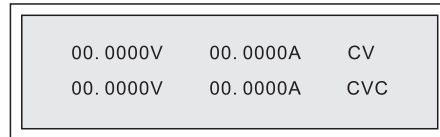

4.1.10.5 定电流保护功能(CC TO CV)

当定电流保护功能被启动且量测进入定电压模式(CV)，电源便会进入定电流保护模式(CC TO CV Protection)，电源将自动关闭输出电压电流，并出现以下画面，按下  键可解除保护画面及蜂鸣器状态。

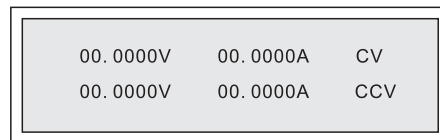

4.1.10.6 过温保护功能

当电源的温度超过保护限值时，电源便会进入过温保护模式，电源将自动关闭输出电压电流，并出现以下画面，按下  键可解除保护画面及蜂鸣器状态。

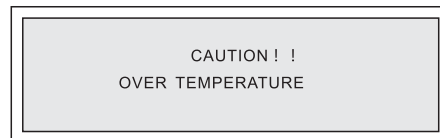

4.1.10.7 短路保护功能

每款机型，在检测到其进入CC模式，回读电压小于等于0.7V，视为输出短路，此时电源将关闭输出，并出现以下告警画面，按下  键可解除保护画面及蜂鸣器状态。

注：此短路保护仅在电流回读值大于2A时判断。

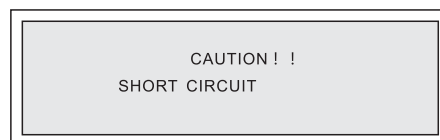

4.1.10.8 硬件过压保护功能

每款机型，当检测到电源的输出大于硬件电路设置的电压时，电源便会进入硬件过压保护模式，电源将自动关闭输出电压电流，并出现以下画面，按下  键可解除保护画面及蜂鸣器状态。

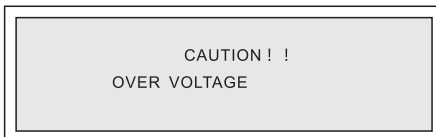

4.1.11 SERIES/PARALLEL / 串并联设置



警告!

- 串并联不可混合使用。
- 不同机型不可作串/并联使用。
- 使用串/并联时请确定断路器容量是否足够，且电源线的地线请接在同一点，并确保接地。
- 多机串联时，请务必移除均流线，否则将严重损坏电源。

4.1.11.1 主从串并联通讯口连接方式

当直流电源做主从串联时，后面板SYSTEM BUS接线如下图a。

当直流电源做主从并联时，除需连接后面板SYSTEM BUS外，如需均流，接线如图b。

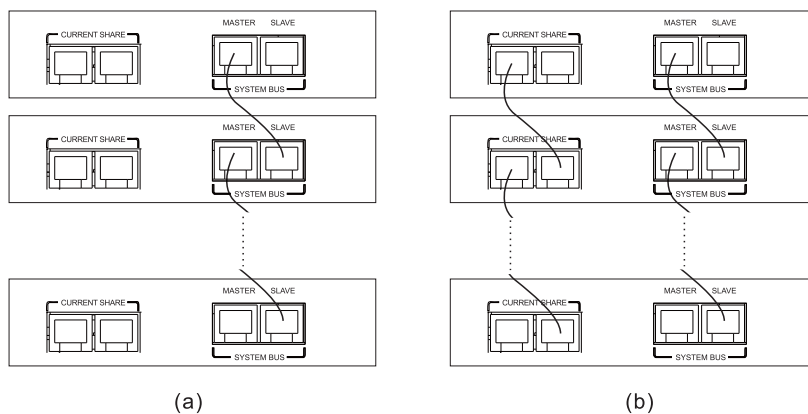

4.1.11.2 串并联系统操作设定方式

4.1.11.2.1 设定SLAVE



注意!

- 直流电源欲操作于主从模式时，需先设定SLAVE，最后再设定MASTER。
- 不同机型可串/并电源的总台数请参考Appendix A，以下操作说明以3台从机为例。

按上图进行接线完成后，选定一台为MASTER，另外几台分别为SLAVE 1~SLAVE 3，必须先设定SLAVE的状态再设定MASTER，使MASTER在SLAVE都设定完成的状态下去搜寻所有的SLAVE，以达成控制。

设定SLAVE方式为在主画面按下 **Menu** + **▽** 进入5. SERIES/PARALLEL界面，通过 **△**/**▽** 键，将其设定为SLAVE 1，再将其他两台依上述方法设定为SLAVE 2以及SLAVE 3，从机设定好后，锁定在如下界面，只能通过小数点键退出界面，也即退出主从控制。

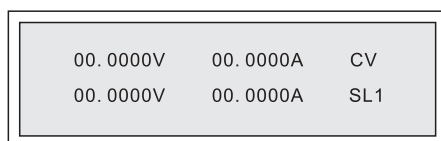

4.1.11.2.2 设定MASTER

设定MASTER的方式为在主画面按下 **Menu** + **▽** 进入5. SERIES/PARALLEL界面，首先将其设定为MASTER，按下 **Enter** 后设定串并联模式，如下图设置为并联，按下 **Enter** 键后MASTER会去搜寻所有的从机SLAVE，如下图所示：

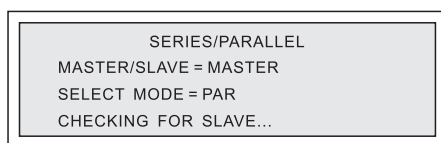

若通讯正常则会出现系统内从机数量：

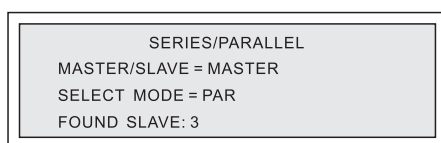

当前界面按下 **Enter** 键，主机则会显示如下选择界面，用户可设定电源关机之后是解除主从关系，还是保持主从关系。

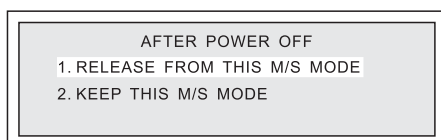

按下  键，主机进入设定主界面：

000.000V	Σ 000.00A	OFF
000.000V	Σ 042.00A	

从机则会锁定在以下界面，只能由主机操作，无法单机操作：

00.0000V	00.0000A	CV
00.0000V	21.0000A	SL1

若要退出串并联操作，需将直流电源的输出关闭，进入主机的串并联模式将其设定为OFF可解除主从状态。

MASTER有以下两个方面的功能：

1. 发出命令给所有的SLAVE，如电压设定、电流设定等，即SLAVE内的电压电流设定以及LIMIT值都将来自MASTER，SLAVE原先的设定均失效；
2. 接收所有来自SLAVE量测值，由MASTER统计所有量测值并显示于主界面上。另外，当有电源发生保护时，将会在其主界面显示告警信息，所有电源将关闭输出，并退出主从关系。

注意!

- 多台直流电源做串/并联时，只能有一台直流源做MASTER，其余均需设成SLAVE。
- 若SLAVE设定为相同时(如SLAVE 1 & SLAVE 1)，会发生通讯错误，当出现这种错误时，先跳出串并联操作，将SLAVE设为不同，才可继续做串并联操作。

说明

- 在选择保持主从关系后，再次开机时先开从机再开主机即可省去重新设定的步骤。

4.1.11.2.3 串并联错误信息列表

若主从通讯线错误或者通信不正常，则在主机搜索从机时出现如下界面：

```
SERIES/PARALLEL
MASTER/LAVE = MASTER
SELECT MODE = PAR
ERR: FOUND NON SLAVE
```

若在运行过程中主机报警并在主界面右下角显示OUT，可能是由于以下问题导致：





```
000.000V  Σ000.00A  OFF
050.000V  Σ100.00A  OUT
```

1. 有从机名称一样；
 2. 不止一台主机；
 3. 在主机控制从机的过程中，通信中断；
 4. 从机输出不同步；
 5. 从机关闭不同步；
- 可在发生报警时按照以上提及的原因一一检查排除。

4.1.12 TIMER CONTROL / 定时控制

按下  进入菜单，进入TIMER CONTROL界面。

```
TIMER CONTROL = OFF
TIMER = 00: 00: 00
```

按下  或  按键可切换光标处显示，选择后，按下  键，就可选择启动或是关闭计时器的设定，然后光标下移，此时可设定电源输出时间，最大时间为99时59分59秒，时间设定完毕后，按下  键，返回主界面，然后用户可设定电压及电流，并打开输出，按下  键，此时界面会出现TIMER倒数，倒数至时间为零后会自动关闭输出。

注: 定时功能在主从模式下不起作用。

```
TIMER = 00: 10: 50
00.0000V  00.0000A  OFF
12.0000V  10.0000A
```



注意!

- 实现计时功能时，只能执行一次，待倒计时到0之后，关闭输出，输出置为OFF。

4.1.13 SPECIAL TEST FUNC / 特殊测试功能

1. PROGRAM MODE

按下 **Menu** 进入菜单，进入SPECIAL TEST FUNC界面。

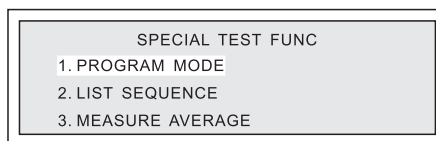

在此界面，按下 **Enter** 键进入如下界面，进入List波形编辑功能菜单：

- 1.EDIT FILE FORMAT 选择List文件格式；
- 2.EDIT LIST FILE 编辑List文件；
- 3.LOAD LIST FILE 执行List文件。

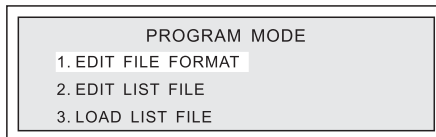

- (1) 进入EDIT FILE FORMAT子界面；
- (2) 显示屏显示以下可供选择的List模式：

2*150 Steps	设置2个变量150步的List1
3*25 Steps	设置3个变量25步的List2
5*30 Steps	设置5个变量30步的List3

- (3) 按下 **Enter** 确认；
- (4) 按 **▽ + Enter** 选择EDIT LIST FILE并确认；
- (5) VFD显示如下图，文件名为LIST FILE 1；

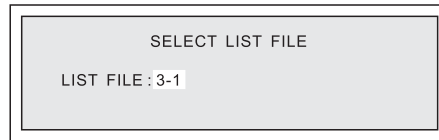



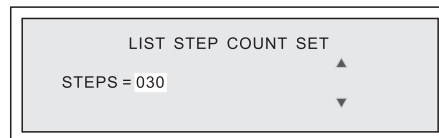

(6) 按下  键，VFD显示 LIST STEP COUNT SET，按   +  确定List 1总步数Steps;

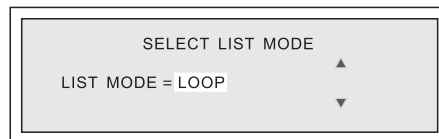

(7) VFD显示LIST MODE SELECT，按   键选择工作模式，其中：

- a) LOOP 表示LIST档循环执行；
- b) CONT表示LIST档执行完全部步数后，停止执行，直到下一次触发；
- c) STEP 表示LIST档每执行一步都会停止，直到下一次按  键触发；



(8) VFD显示如下内容，按  ~  +  设定电压开始值(Vstart)，电压结束值(Vend)，电压变化斜率(Vrate)；

注：斜率范围0.00001V/s~4000V/s。

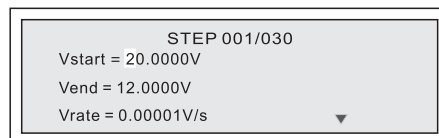

(9) 按下  按键，进入下一页，设定限流值(Iset)以及持续时间(Tcon)，设置方法同上；

注：持续时间范围0s~99999.999s

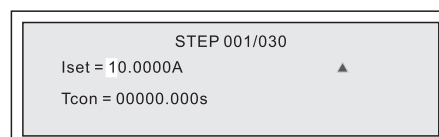

- (10) 设置完成后，按下 **Enter** 键，进入STEP 2的设置，方法同STEP 1的设定；
- (11) 电源重复8、9、10步骤直到设定完所有步数；
- (12) 根据需要，重复5-10步编辑其他的步骤；
- (13) 选择LOAD LIST FILE并确认；

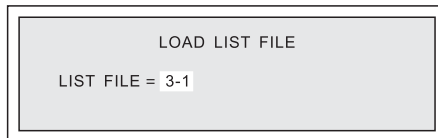

- (14) 电源进入LIST模式，显示界面如下：

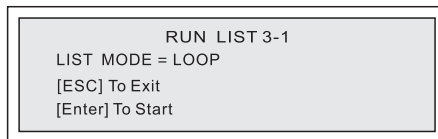

按下 **Enter** 键，便开始输出编辑的波形。

2. LIST SEQUENCE

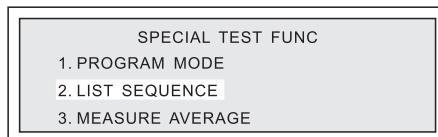

在此界面，按下 **Enter** 键进入如下界面，进入SEQUENCE编辑菜单：

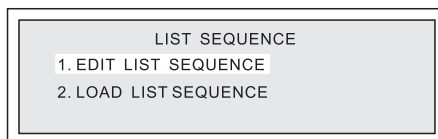

VFD显示 如下图，按下 $\Delta \nabla + \text{Enter}$ 键确定SEQUENCE文件名：

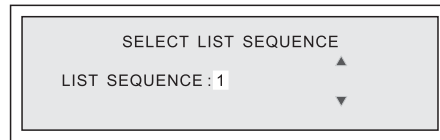

按下 Enter 键，VFD显示 SEQUENCE STEP COUNT SET，按 $\Delta \nabla + \text{Enter}$ 键确定List 1总步数：

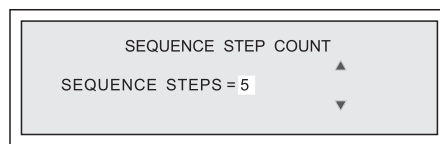

VFD显示 SELECT SEQUENCE MODE，按 $\Delta \nabla$ 键选择工作模式，其中：

- a) CYCLE 表示SEQUENCE按周期循环执行；
- b) STEP 表示SEQUENCE每执行一步都会停止，直到下一次按 Enter 键触发；

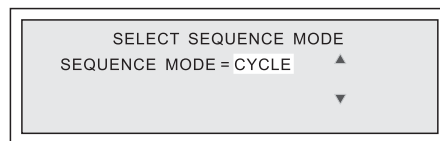

按下 Enter 键，选择CYCLE 模式，按 $0 \sim 9 + \text{Enter}$ 键确定循环次数，CYCLE 的范围是0~9999999，0代表无限循环；

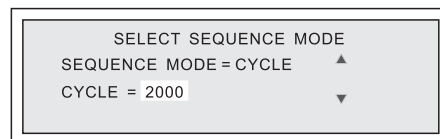

按下 ∇ 键，选择 LIST 文件，SEQUENCE 中的每一步均是 PROGRAM MODE 中编辑好的 LIST文件。按 $0 \sim 9 + \text{Enter}$ 键来确定当前STEP的运行次数：

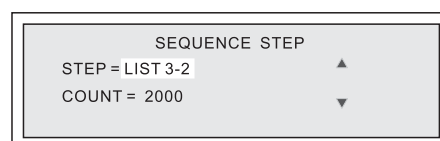

选中2.LOAD LIST SEQUENCE，按下 **Enter** 键载入SEQUENCE数据：

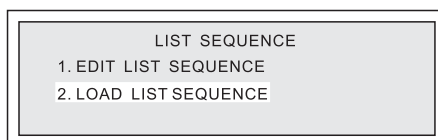

选择LOAD LIST SEQUENCE并确认：

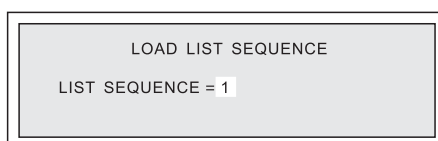

电源进入LIST模式，显示界面如下：

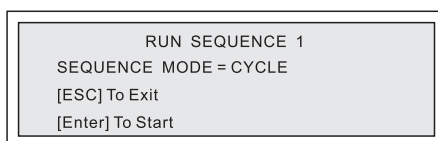

按下 **Enter** 键，便开始输出编辑的波形。

3. MEASURE AVERAGE

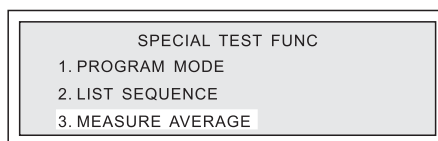

按下 **Enter** 键进入如下界面：

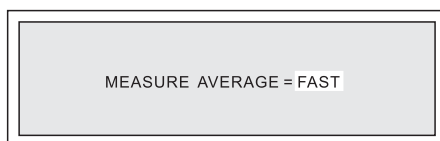



在此模式下，若是待测物有剧烈的电压电流变化，可改变平均测量次数来让VFD的显示值更加稳定。显示频率有FAST(快)/MEDIUM(中)/SLOW(慢)可供选择。

4.1.14 ADDITIONAL FUNCTIONS/ 定制新增功能

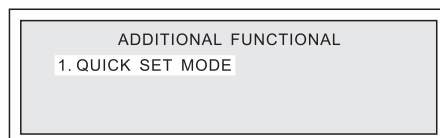

1. QUICK SET

按下  进入菜单，进入ADDITIONAL FUNCTIONAL界面。

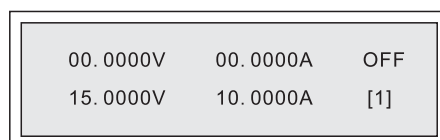

按下  键，进入1. QUICK SET MODE子界面，按下  键，电源进入快速调用设置模式，并跳转至如下主界面，默认为第1组存储值：



此时，若用户需切换设置的参数，通过前面板的数字键  ~  即可实现，同时右下角的组别也将会同步切换显示。若退出快速调用模式，按下  键即可，支持在线切换输出。

说明

- 用户需先将参数保存后才能调用；
- 在快速调用模式下，仅  与  键有效，其他按键包括旋钮均被锁定。

4.2 后面板说明

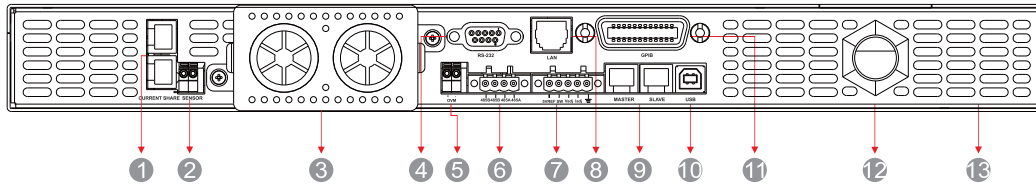

1U电源后面板

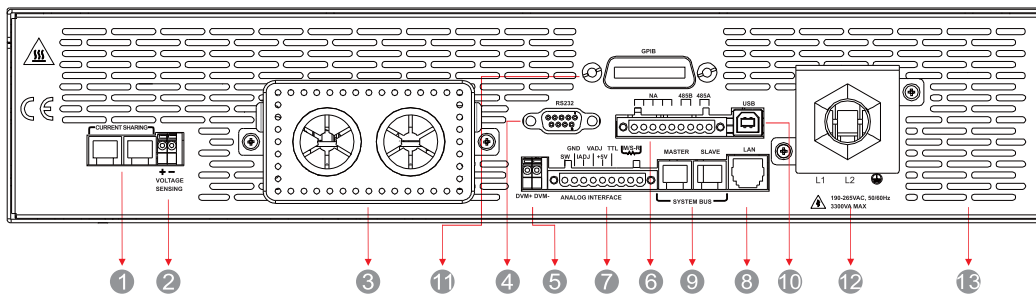

2U电源后面板

- ① 均流接头，多机并联时连接可自动均流(系统输出电流10A以上)；
- ② SENSOR，远端补偿连接端子；
- ③ DC输出端子，左负右正；
- ④ RS-232，9PIN D型公座接头，传输PC对设备的控制命令，供远程操作；
- ⑤ DVM连接端子；
- ⑥ RS-485 通讯接口；
- ⑦ ANALOG INTERFACE 信号连接端子，分为地、SW (外部模拟量控制电源的输出，高于1.2VDC为ON，低于1.2VDC为OFF)、Iadj (外部模拟量控制电源设定限流值)、Vadj (外部模拟量控制电源设定电压值)以及5V电压；
- ⑧ LAN 通讯接口；
- ⑨ SYSTEM BUS-MASTER/SLAVE 主从控制，作串并联数据传送用；
- ⑩ USB 通讯接口；
- ⑪ GPIB 通讯接口；
- ⑫ AC 电源连接端子，注意接地；
- ⑬ 风扇风道出口，不可堵住风扇风道出口，以免机器内部的热量无法散出。

4.2.1 输入连接



警告!

- 接触DC输出端子或者AC输入端子之前，必须切断AC输入！
- 务必用黄绿线将Ⓧ接口接入地面，否则会发生严重的触电危险！
- 交流源的连接有一定的危险性，请由专业人士进行！
- 本产品附属电源线直径为AWG10，并通过安全认可，可满足本机额定电性规格的使用，如另行更换导线或加装延长线时，需由经验丰富的工程师加以确认后才可以使用，以免误装导致危害！



说明

- 建议在输入线端选配断路器，输入电压为110/120VAC时，断路器规格为110/120VAC，25A；输入电压为220/230/240VAC时，断路器规格为220/230/240VAC，15A，断路器可当作一种紧急断电装置来使用，断开断路器将断开设备的交流输入。

输入连接线步骤：

1. 将随机AC线缆剥开35mm的长度，每根线缆的绝缘层剥去10mm；
2. 用十字螺丝刀将锁端子盖板的3个螺丝松开，取下盖板；
3. 旋开电缆固定头的母头；
4. 将输入的火线(L)，零线(N)，地线按图示方向穿过线缆固定头，然后插入对应的接线端子插口内。
5. 用十字螺丝刀将接线端子顶端内的螺丝拧紧，以锁紧线缆。
6. 将线缆整理整齐，装回端子盖板，并旋紧固定头。

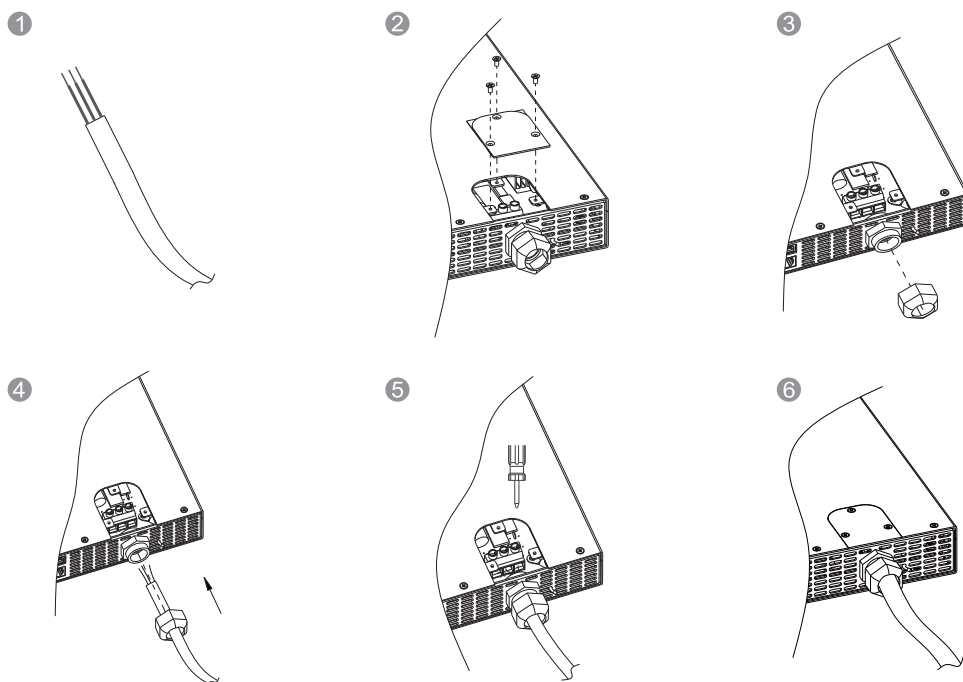

2U电源输入连接线步骤：

1. 将随机AC线缆剥开25mm的长度，每根线缆的绝缘层剥去7mm；
2. 旋开电缆固定头的母头；
3. 将输入的火线L1/L2，地线按图示方向穿过线缆固定头，然后插入对应的接线端子插口内。
4. 用十字螺丝刀将接线端子顶端内的螺丝拧紧，以锁紧线缆。
5. 将线缆整理整齐，装回端子盖板，并拧紧固定头。

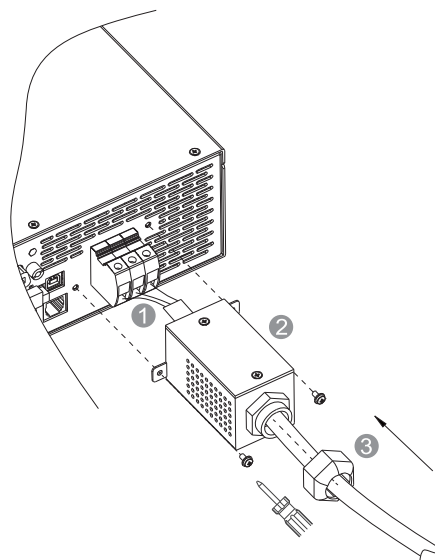

4.2.2 输出连接



警告!

- 在进行负载的连接时必须关闭直流电源；
- 所有的螺丝必须拧紧。



注意!

在进行负载连接时需考虑以下因素：

- 导线的载流能力；
- 导线的绝缘值至少等于直流电源的最大输出电压；
- 最大线长以及压降；
- 负载线的噪声及阻抗效应。

输出端的组装方式：

1. 将输出线最前面去皮(裸露长度约1cm)，并使用O型端子作压接；
2. 将线缆穿过防护罩，用十字螺丝刀将其与输出端子锁紧；
3. 锁紧防护罩。

兼顾导线的温度与压降，可参照以下表格选择线缆：

安全电流(A)	最小线缆规格		安全电流(A)	最小线缆规格	
	截面积(mm ²)	AWG		截面积(mm ²)	AWG
13~16	1.5	14	125~160	50	0
16~25	2.5	12	160~190	70	000
25~32	4	10	190~230	95	0000
32~40	6	8	230~260	120	250 kcmil
40~63	10	6	260~300	150	300 kcmil
63~80	16	4	300~340	185	400 kcmil
80~100	25	2	340~400	240	500 kcmil
100~125	35	1	400~460	300	600 kcmil

1U电源输出连接图

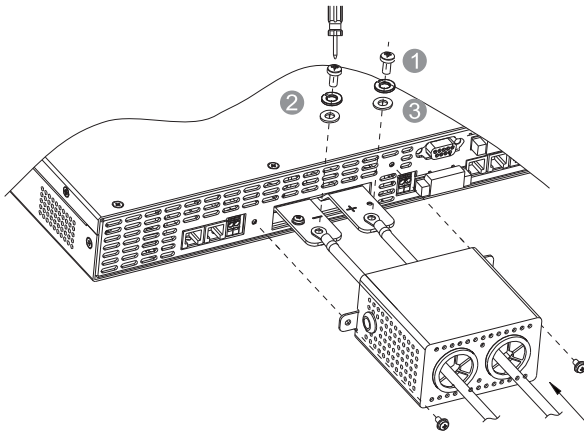

- ① M6*12螺丝;
- ② 弹簧垫片;
- ③ 垫片;

2U电源输出连接图

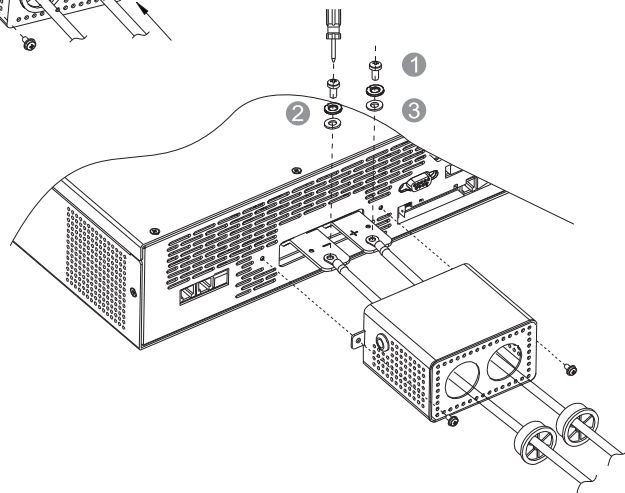

4.2.3 远端补偿

4.2.3.1 连接方式

1. 正确的连接远端补偿线缆可确保负载两端的电压即为设定电压，最多可以补偿5V。
2. 正确的接法如图，在负载端之正负接头上另外接两条线连接至后面板的Sensor+与Sensor-，连接线为22 AWG，线芯的绝缘层剥去5~7mm。

4.2.3.2 sensor wire 未接或极性接反

如果没有接远端补偿线缆，其误差值可能会变大，所以请正确的连接远端补偿线缆，在实际应用上，即便是线压降可忽略，也最好将远端补偿线缆连接至输出端子。

远端补偿线缆的极性必须连接正确，即“+”端连接至输出端子的“+”端，或是连接至此端子的连接线上；而“-”端连接至输出端子的“-”端，或是连接至此端子的连接线上。若极性接反，则会将输出降至0V。

说明：此时并不会因极性接反而烧毁，只需依下列步骤执行即可：

1. 先关机；
2. 正确连接远端补偿线缆；
3. 重新启动。

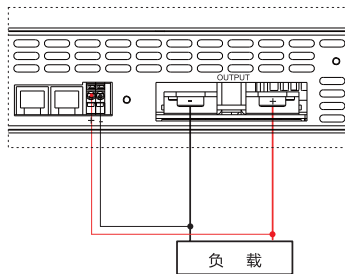

1U电源 sensor wire 的正确连线

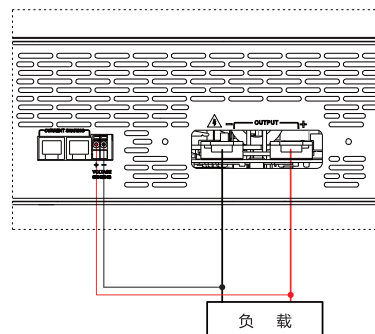

2U电源 sensor wire 的正确连线

4.2.4 DVM

DVM为数字电压表，使用前注意与待测物极性的正确连接，建议连接为22AWG，线芯的绝缘层剥去5~7mm。

5 典型应用

5.1 外部设定

外部设定功能可通过 EXTERN CONTROL 菜单实现。

可编程直流电源提供外部电压(0~5V)/电阻(5~10K)来控制电源的电压及电流的输出，接线方式可参考下图：

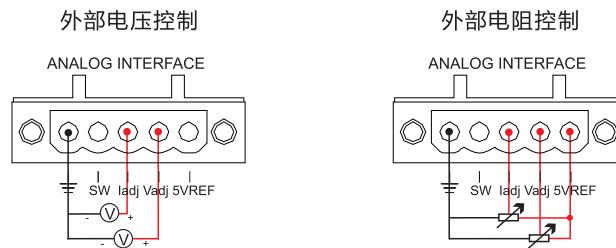

通过 EXTERN CONTROL 菜单来选择外部电压控制还是电阻控制，并根据外部的数值等比例设定电压和电流值。

00.0000V	00.0000A	OFF
12.0000V	10.0000A	EXV

5.2 计数器功能

计数器功能可通过 TIMER CONTROL 菜单实现。

在此选项内将功能选为 ON 后，就开启了计时器功能，设定好时间回到主界面，然后根据需要设定电压与电流值，按下 **Enter** 键，画面将出现倒数计时，倒数至输出时间为 0 后将自动关闭输出。此功能可用在产线及其他无人操作的环境中，无需人为时时关注，完成任务，便自动停止输出，而且电源自身具备的完整保护功能体系，确保了使用的安全。

TIMER = 00:10:50		
00.0000V	00.0000A	OFF
12.0000V	10.0000A	

5.3 超低压模式功能

此功能可用于测试断路器或者线缆的载流能力。测试电路连接如下：

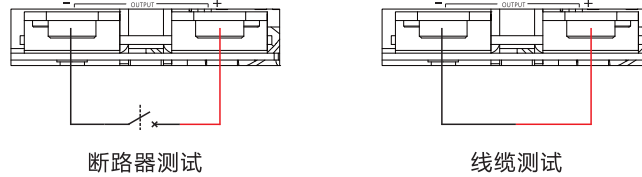

按下 **Menu** 键进入菜单，使用 **△▽** 键选择 2.OUTPUT SETTING 子界面。

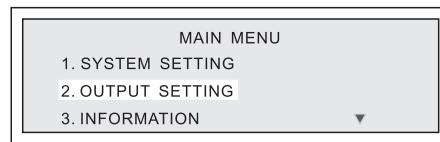

按下 **Enter** 键，使用 **△▽** 键选择 5.ADVANCED FUNC子界面。

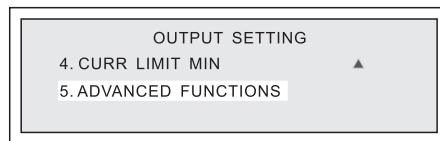

按下 **Enter** 键，使用 **△▽** 键选择 2.SHORT MODE子界面。

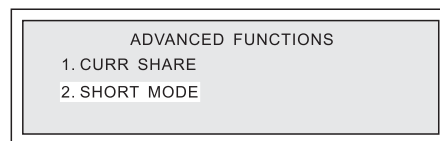

按下 **△▽ + Enter** 键，将此选项设置为 OFF 之后便可进行线缆测试。

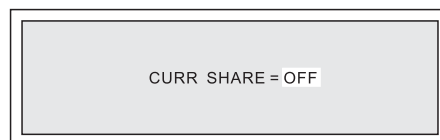

需要注意的是，该设定在电源断电之后会被保存，如客户在接下来不再使用超低压模式，切记将此设定设置为 ON，用来保护电源以及待测物。

5.4 主从并联连接

以下为主从并联输出时的接线方式，供参考，用户可根据实际使用环境接线，并确保接线方便可靠。注：以SP75VDC3000W为例。

并联输出连接方式

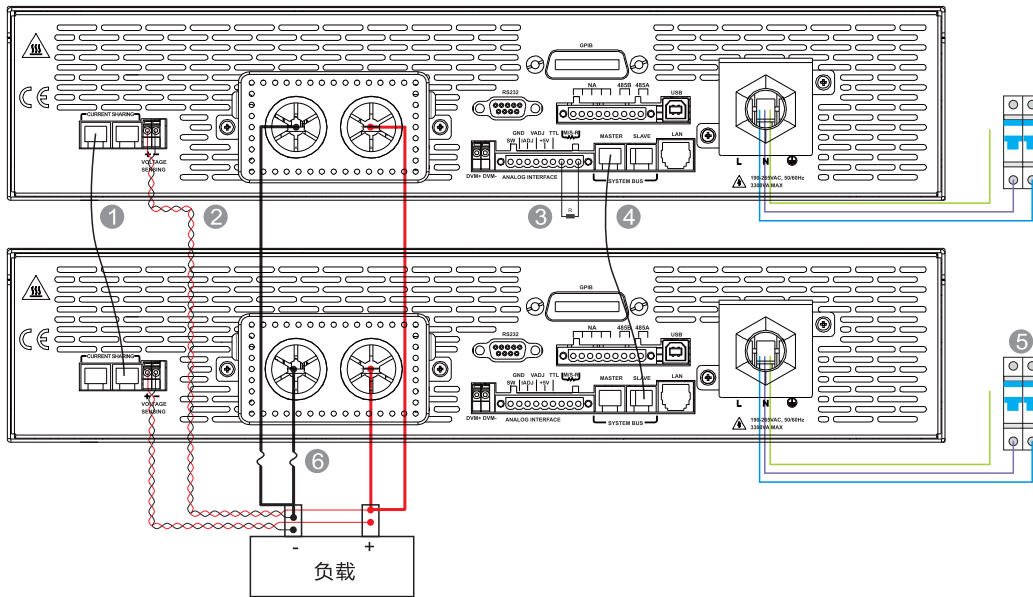

- ① 均流线缆，电源并联输出时连接，串联输出时务必移除，否则将严重损坏设备；
- ② 远端补偿线缆，连接时注意正负极不要接反；
- ③ 终端电阻，在主从系统的首或尾连接，阻值为120Ω；
- ④ 系统通讯线缆，设置主从机时需连接此线缆；
- ⑤ AC 断路器规格如下表：

功率	600W/1000W/1200W	1500W/1600W	
断路器	110/120VAC, 20A 或 220/230/240VAC, 15A	110/120VAC, 25A 或 220/230/240VAC, 15A	
功率	2000W	3000W	3000W
断路器	220/230/240VAC, 20A	220/230/240VAC, 25A	220/230/240VAC, 30A

- ⑥ 建议在每台电源的输出侧连接保险丝，推荐规格：保险丝的电压额定值/电流额定值分别为电源输出电压最大值/电流最大值的1.5倍。

串联输出连接方式

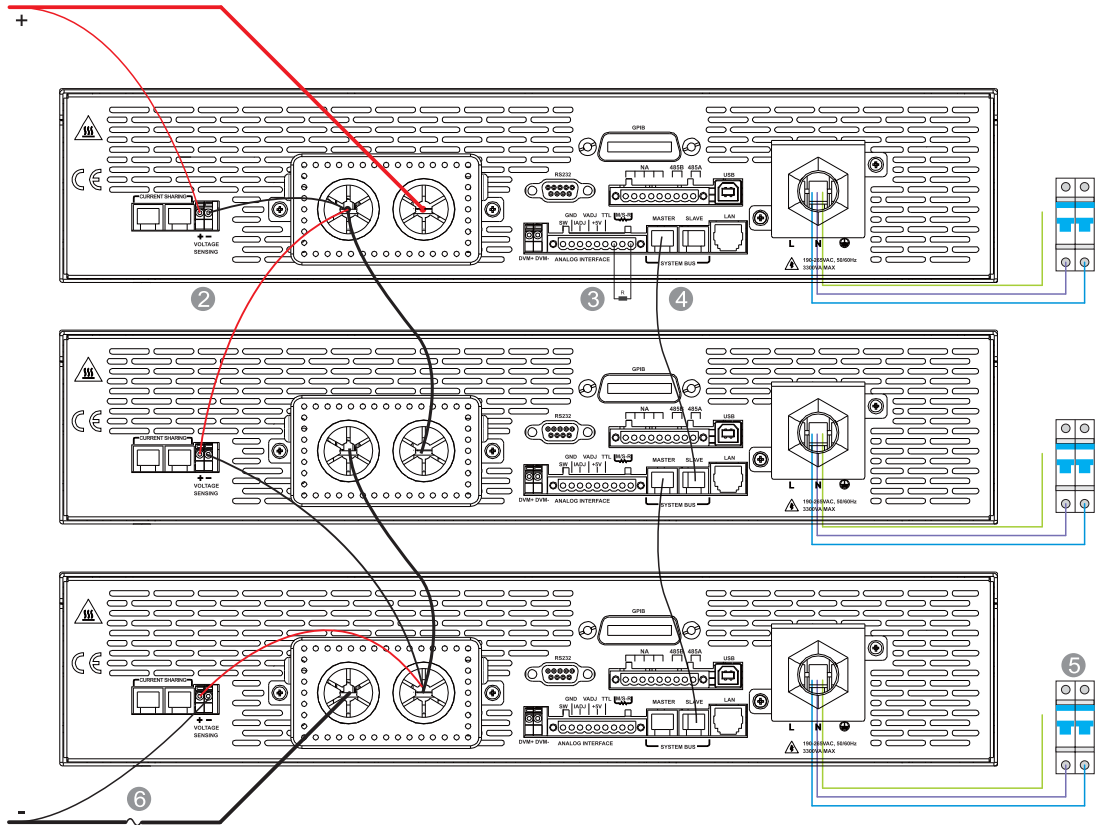

连接好电源线，并分别确定两台电源在空载的情况下输出均正常，电源电压回读值与外接电压表的误差在标准要求以内。若精度符合，打开负载，设定电压与电流值，并确定电源的电压回读值与电流回读值均显示正常，电源电压回读值与外接电压表的误差在标准要求以内，电源电流回读值与外接表的误差在标准要求以内，且电源无其他异常情况。

5.5 List波形编辑功能

此系列电源的List波形编辑思路如下图。电源现支持30步5个变量的波形编辑，5个变量分别为开始电压(Vstart)，结束电压(Vend)，斜率(Vrate)，限流值(Istart)，以及结束电压的持续时间(Tcon)。用户可按照如下思路将目标波形进行分解，然后将数据分别填入List编辑文件内即可。

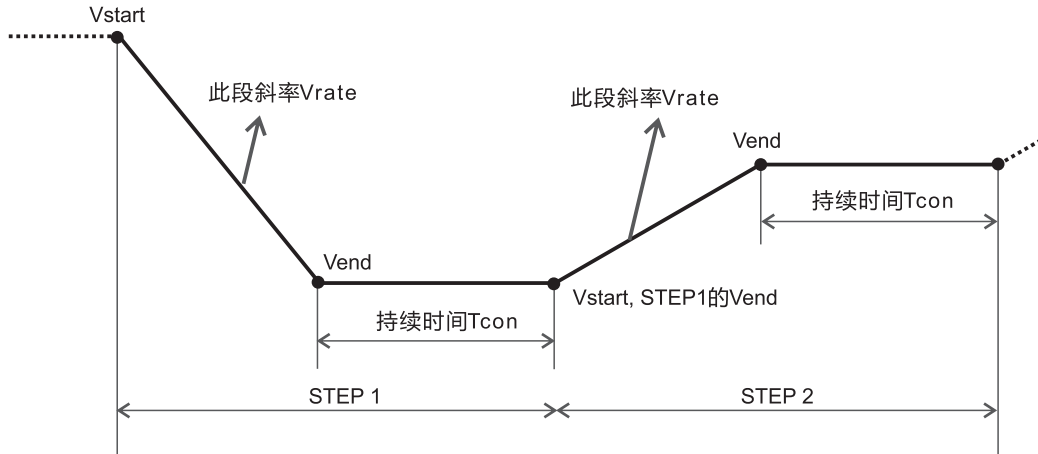

用户可按照上述思路将波形进行分解，按下 **Enter** 键进入 7. SPECIAL TEST FUNC，选择菜单 2. EDIT LIST FILE 来编辑 List 文件。

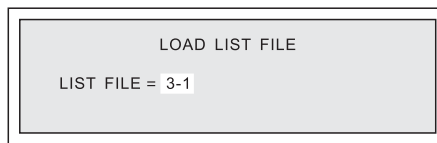

编译完成后，进入 3. LOAD LIST FILE 输出编译好的波形。

6 SCPI 通信协议

SCPI 是一种用于可程序设计仪表的标准指令，用于定义一套通讯时的指令规则。本系列直流电源支持 SCPI 通讯协议，采用两大类指令：基本指令 (IEEE-488.2 公用指令集) 和全天科技可编程直流电源的指令集。指令以回车键结尾。

6.1 相关指令描述

6.1.1 IEEE-488.2公用指令集

该指令包括了在IEEE488.2标准中所定义的通用功能，该组指令以星号(*)开始，没有层次结构。

***IDN?**

该指令可以读取电源的相关信息，如生产商，产品型号，产品序号，软件版本号。

6.1.2 全天科技可编程直流电源所指定的指令

6.1.2.1 系统指令

SYST:ETR

该指令设置电源从外部模式回到远程模式，设置成功后，电源主界面右下角出现“REM”。

SYST:LOC

该指令设置电源从远程模式回到本地模式，设置成功后，可通过前面板控制电源。

SYST:RTE

该指令设置电源从远程模式回到外部模式，设置成功后，可通过后面板模拟量输入端口控制电源。

SYST:REC:DEF

该指令将电源恢复为出厂设置。

6.1.2.2 设置指令

VOLT <value>

CURR <value>

该指令用来设定电源的电压(V)以及电流值(A)。

OUTP <value>

该指令用来打开电源的输出(1)，或者关闭电源的输出(0)。

6.1.2.3 测量指令

MEAS:VOLT?

MEAS:CURR?

MEAS:DVM?

该指令用来回读电源的电压值(V)，电流值(A)或者DVM测量值(V)。

6.1.2.1 其他指令

ASWRS?

该指令用来请求电源的告警信息。告警信息表如下。

告警代码	说明	告警代码	说明
0	正常运行	9	硬件过压保护
1	OVP	A	短路保护
2	OCP	B	风扇故障
3	OPP	C	过温保护
4	CVC (CV TO CC)	D	NTC故障
5	CCV (CC TO CV)	E	初级侧告警
6	主从通讯异常	F	EEPROM告警

ASWRC 0

该指令用来清除蜂鸣器的告警声音。

OUTP?

该指令用来查询电源的输出状态，ON返回1，OFF返回0。

VOLT?

CURR?

该指令用来查询电源的电压设定值(V)，或者电流设定值(A)。

VOLT?MAX

CURR?MAX

VOLT?MIN

CURR?MIN

该指令用来查询电源设定的最大/最小电压(V)/电流值(A)限值。

PORT:OVP <value>
PORT:OCP <value>
PORT:OPP <value>
PORT:CCCV <value>
PORT:CVCC <value>

该指令用来开启(1)/关闭(0)电源的对应保护功能。

PORT:OVP:VOLT <value>
PORT:OCP:CURR <value>
PORT:OPP:POWR <value>

该指令用来设定对应项目的保护值。

PORT:OVP:VOLT <value>
PORT:OCP:CURR <value>
PORT:OPP:POWR <value>

该指令用来查询对应项目的保护值。

PORT:CURR:SHARE <value>

该指令用来开启(1)/关闭(0)电源的均流功能。

PORT:ON:STATE <value>

该指令用来设定电源的开机状态。0 (OFF), 1 (LAST), 2 (USER)。

PORT:ON:STATE?

该指令用来查询电源的开机状态。0 (OFF), 1 (LAST), 2 (USER)。

SYS:USER:VOLT <value>
SYS:USER:CURR <value>

该指令用来设定USER状态下电源的电压设定值(V)，或者电流设定值(A)。

SYS:USER:VOLT?
SYS:USER:CURR?

该指令用来查询USER状态下电源的电压设定值(V)，或者电流设定值(A)。

PTYPE <value>

该指令用来设定电源的状态。0 (Master), 1 (Slave1), 2 (Slave2), 3 (Slave3)。

PMODE <value>

该指令用来设定电源的连接状态。0 (单机), 1 (并联), 2 (串联)。

SBEEP <value>

该指令用来开启(1)/关闭(0)蜂鸣器声音。

POWER?

该指令用来查询电源输出功率。

6.1.2.5 RS485通讯方式下的指令

用RS485通讯方式发送指令时, 需先发送一次电源的地址, 电源返回OK的指令, 之后所有的操作指令与上述章节列举的格式一致。

例: 设定地址为2的电源的电压值为10V。

发送指令 CADDR 2

电源返回OK, 表示电源已经与电脑建立通讯连接。

发送指令 VOLT 10

电源无返回值, 此时电源电压设定为10V。

6.1.2.6 List文件指令

LFILE <value>

该指令用来设置List文件格式。

1 或 2 (2*150 steps), 3 或 4 (3*25 steps), 5 到 14 (5*30 steps)。

LTOTA <value>

该指令用来设置List文件的总步数。

LMODE <value>

该指令用来设置List文件的运行模式, 0 (CONT), 1 (STEP), 2 (LOOP)。

LSTEP <value>

该指令用来指定STEP。

LVOLT <value>

该指令用来设定电压Vset。

LTCOM <value>

该指令用来设定持续时间Tcon, 参数范围00000.000~99999.999(s)。

LSAVE <value>

该指令用来保存List文件设定。

LLOAD <value>

该指令用来下载List文件到电源。

LRUNO <value>

该指令用来运行List文件。

例如

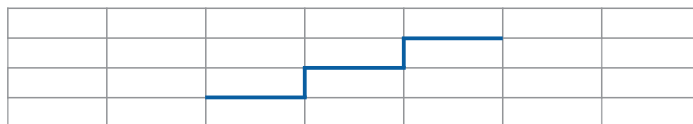

LFILE 1	选择List文件格式为2*150 steps
LTOTA 3	List 1共3步
LMODE 0	List 1运行模式为CONT
LSTEP 1	编辑Step 1
LVOLT 5	电压Vset设置为5V
LTCOM 1000	持续时间Tcon设置为1000s
LSTEP 2	编辑Step 2
LVOLT 10	电压Vset设置为10 V
LTCOM 1000	持续时间Tcon设置为1000s
LSTEP 3	编辑Step 3
LVOLT 15	电压Vset设置为15 V
LTCOM 1000	持续时间Tcon设置为1000s
LSAVE	保存List 1
LLOAD	下载List 1
LRUNO	运行List 1

LCURR <value>

该指令用来设定电流Iset。

例如

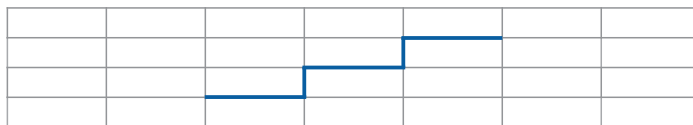

LFIL 3	选择List文件格式为3*25 steps
LTOT 3	List 3 共3步
LMO 0	List 3运行模式为CONT
LST 1	编辑 Step 1
LV 5	电压Vset设置为5 V
LC 10	电流Iset设置为10 A
LTC 1000	持续时间Tcon设置为1000s
LST 2	编辑 Step 2
LV 10	电压Vset设置为10 V
LC 10	电流Iset设置为10 A
LTC 1000	持续时间Tcon设置为1000s
LST 3	编辑 Step 3
LV 15	电压Vset设置为15 V
LC 10	电流Iset设置为10 A
LTC 1000	持续时间Tcon设置为1000s
LSAVE	保存List 3
LLOAD	下载List 3
LRUNO	运行List 3

LVSTR <value>

该指令用来设置开始电压Vstart。

LVEND <value>

该指令用来设置结束电压Vend。

LVRAT <value>

该指令用来设置电压斜率Vrate，参数范围0.00001~4000(V/s)。

LSTOP <value>

该指令用来退出List文件的运行。

例如

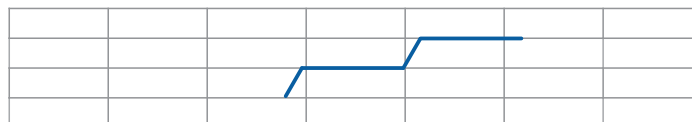

LFILE 5	选择List文件格式为5*30 steps
LTOTA 2	List 5 共2步
LMODE 0	List 5运行模式为CONT
LSTEP 1	编辑Step 1
LVSTR 5	电压Vstart设置为5 V
LVEND 10	电压Vend设置为10 V
LVRAT 2000	电压斜率Vrate设置为2000V/s
LCURR 10	电流Iset设置为10 A
LTCOM 1000	持续时间Tcon设置为1000s
LSTEP 2	编辑Step 2
LVSTR 10	电压Vstart设置为10 V
LVEND 15	电压Vend设置为15 V
LVRAT 2000	电压斜率Vrate设置为2000V/s
LCURR 10	电流Iset设置为10 A
LTCOM 1000	持续时间Tcon设置为1000s
LSAVE	保存List 5
LLOAD	下载List 5
LRUNO	运行List 5

6.1.2.7 Sequence文件指令

QFILE <value>

该指令用来设置SEQUENCE文件名称，从0到4。

QSTEP <value>

该指令用来设置SEQUENCE文件Steps总数。

QMODE <value>

该指令用来设置SEQUENCE文件运行模式。0 (CYCLE)，1 (STEP)。

QCYCE <value>

该指令用来设置SEQUENCE文件运行次数。

QSTID <value>

该指令用来指定STEP，从0到29。

QFNUM <value>

该指令用来指定List文件。

7 软件介绍

DC Power Control Panel是全天科技为用户精心编制的一套适用于此系列可编程直流电源的监控软件，该软件安装方便，操作简单，极大提高用户的工作效率。该软件包括SINGLE MODE (单机模式)、MASTER/SLAVE(主从模式)、MULTI SETTING(多台模式)，可根据外部电源的连接情况，在开启软件的同时跳至对应操作界面。

7.1 说明

为了不影响软件的正常运作，请在以下配置的PC上安装该软件：

1. 配备奔腾IV或者以上等级微处理器；
2. Windows XP Service Pack 2 或更高版本的操作系统。

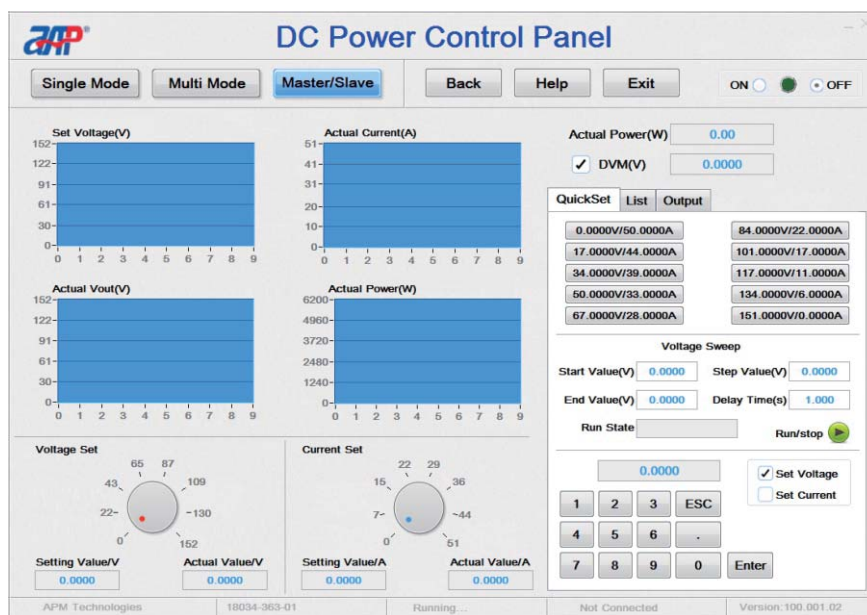

访问<http://www.apmtech.cn/Product-196.html>并在“资料下载”模块下载该软件。

8 常见故障及解决方案

问题	故障原因	解决方案
V, I的不良量测	零件老化导致特性偏差	需要定期校正
输出不在精度范围内	零件老化导致特性偏差	需要定期校正
过温保护(OTP)	1. 环境温度过高 2. 通风孔阻塞	1. 应在环境温度为条件下使用此设备 2. 疏通通风孔
过功率保护(OPP)	输出功率超出规格	移除过载或放宽OPP设定值
过电流保护(OCP)	输出电流超出规格或OCP设定值	移除过载或放宽OCP设定值
风扇故障保护(FAN FAULT)	1. 风扇本身故障 2. 风扇电路异常	若无法重设保护状态, 询问您的代理商来协助
软件版本冲突 (Software Version Conflict)	串并机电源系统内软件版本不一致	询问您的代理商来协助
过电压保护(OVP)	输出电压超出规格或OVP设定值	1. 检查OVP设定值 2. 若无法重设保护状态, 询问您的代理商来协助
短路保护	设备短路或者与设备连接的负载短路	关闭输出, 检查接线是否正确, 确定接线无误后再次上电操作
初级侧告警 (PRIMARY_FAIL)	初级过欠压	用万用表确认输入电压是否满足要求
	初级过温	确定使用环境是否符合要求
	PFC未工作/母线过流	量测BUS电压是否为400VDC, 最好询问您的代理商来协助

9 安装

9.1 电源尺寸概览

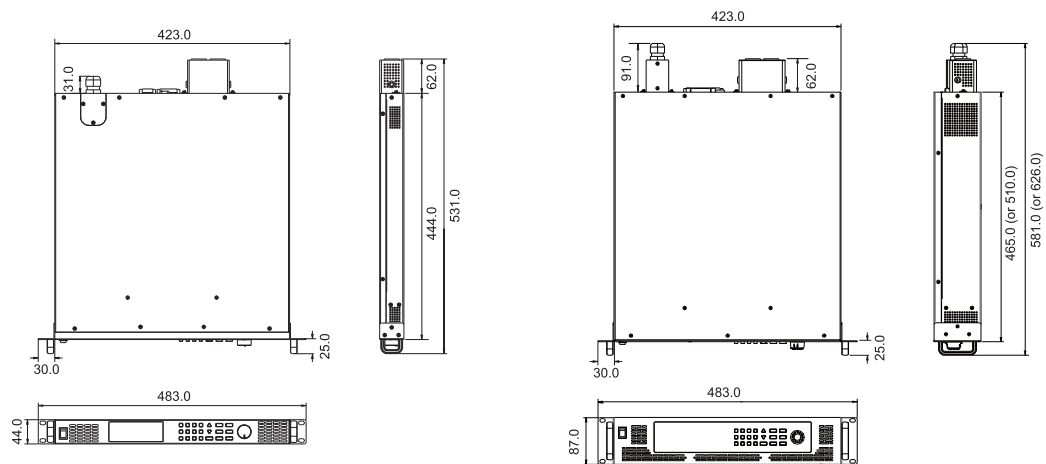

1U电源尺寸图，单位mm

2U电源尺寸图，单位mm

注: 可参考Appendix A技术规格表获取具体型号的尺寸。

9.2 电源上架安装图

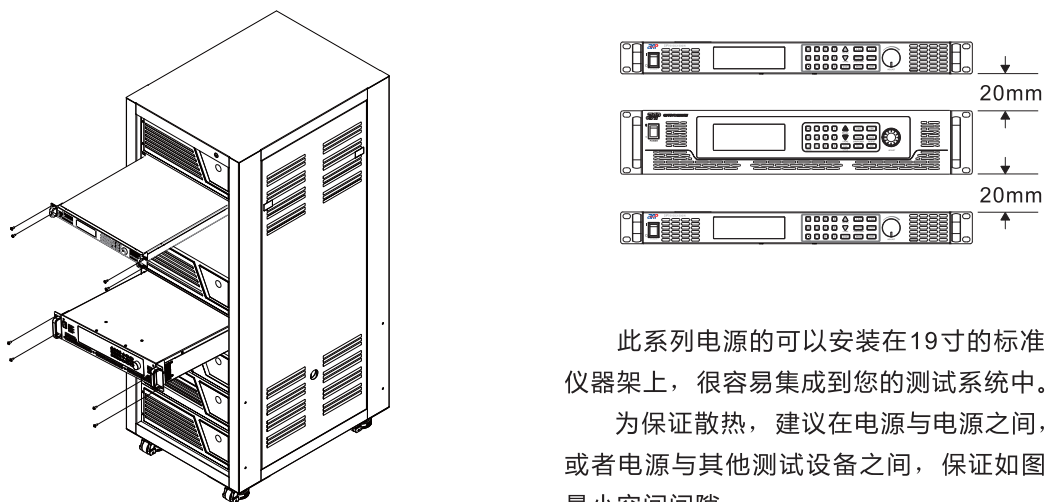

此系列电源的可以安装在19寸的标准仪器架上，很容易集成到您的测试系统中。

为保证散热，建议在电源与电源之间，或者电源与其他测试设备之间，保证如图最小空间间隙。

9.3 握把安装

用户可根据实际需求，参考右图进行握把安装。

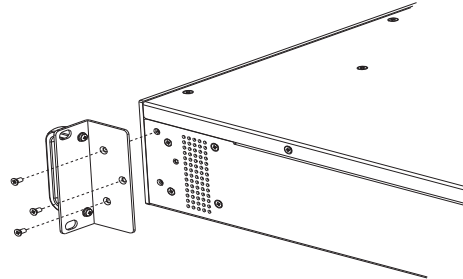

10 回收处理

请勿将本设备及其配件当做生活垃圾丢弃，否则可能导致有害的物质渗进地下水，造成健康的损害。可联系当地政府的相关机关，妥善处理废弃物。更换下来的旧产品或部件，请交由销售商统一管理，全天科技将在一定时间内取回旧产品或者部件。

11 联系我们

如您有关于本公司的可编程直流电源的任何问题，请与我们联系！我们将非常乐于为您解答。以下是我们的联系方式：

全天自动化能源科技(东莞)有限公司
地址：广东省东莞市南城区水濂路联科国际研发中心7栋
邮编：523000
服务热线：+86-769 2202 8588
传真：+86-769 2202 6771
网址：www.apmtech.cn
E-mail: mk@apmtech.cn

Appendix A 技术规格

● 600W in 1U

型号	SP150VDC600W	SP200VDC600W	SP400VDC600W	SP600VDC600W	SP800VDC600W
输入电压	90~265VAC				
输入频率	47~63Hz				
功率因数	>0.98				
输入功率	750VA(MAX)	750VA(MAX)	750VA(MAX)	750VA(MAX)	750VA(MAX)
输出电压范围	0~150V	0~200V	0~400V	0~600V	0~800V
输出电流范围	0~10A	0~8A	0~7.5A	0~5A	0~4A
输出功率范围	0~600W	0~600W	0~600W	0~600W	0~600W
电压负载调整率	15mV	15mV	30mV	30mV	40mV
电流负载调整率	10mA	8mA	15mA	10mA	8mA
电压显示分辨率	1mV	1mV	1mV	1mV	1mV
电流显示分辨率	0.2mA	0.1mA	0.1mA	0.1mA	0.1mA
电压程控分辨率	3mV	3mV	8mV	12mV	16mV
电流程控分辨率	1mA	1mA	1mA	1mA	1mA
电压设定值精度 ^[1]	0.1%+15mV	0.1%+15mV	0.05%+100mV	0.05%+150mV	0.05%+200mV
电流设定值精度	0.1%+10mA	0.1%+8mA	0.1%+15mA	0.1%+10mA	0.1%+8mA
电压回读值精度 ^[1]	0.1%+15mV	0.1%+15mV	0.05%+100mV	0.05%+150mV	0.05%+200mV
电流回读值精度	0.1%+10mA	0.1%+8mA	0.1%+15mA	0.1%+10mA	0.1%+8mA
电压纹波 ^[2]	120mVp-p 40mVrms	120mVp-p 40mVrms	350mVp-p 40mVrms	350mVp-p 40mVrms	500mVp-p 60mVrms
电流纹波 ^[3]	40mA (Full Range) 10mA (TYP Value)	40mA (Full Range) 10mA (TYP Value)	25mA (Full Range) 10mA (TYP Value)	25mA (Full Range) 10mA (TYP Value)	25mA (Full Range) 10mA (TYP Value)
线性调整率 (电压)	0.02%+8mV	0.02%+8mV	0.02%+20mV	0.02%+30mV	0.02%+40mV
线性调整率 (电流)	10mA	30mA	10mA	8mA	10mA
电压温度补偿系数 ^[4]	100ppm/°C				
电流温度补偿系数 ^[4]	150ppm/°C				
DVM 分辨率	1mV	1mV	8mV	12mV	16mV
DVM 精度 ^[1]	0.1%+15mV	0.1%+15mV	0.05%+100mV	0.05%+150mV	0.05%+200mV

型号	SP150VDC600W	SP200VDC600W	SP400VDC600W	SP600VDC600W	SP800VDC600W
工作模式	恒压 (CV) / 恒流 (CC)				
远端补偿	4V MAX				
主从控制	具有				
响应 (电压上升)	≤25ms	≤30ms	≤60ms	≤60ms	≤60ms
响应 (电压下降)	≤400ms (空载) ≤32ms (满载)	≤600ms (空载) ≤50ms (满载)	≤800ms (空载) ≤100ms (满载)	≤1200ms (空载) ≤100ms (满载)	≤1200ms (空载) ≤100ms (满载)
负载瞬态响应时间 ^[5]	≤2ms	≤3ms	≤3ms	≤3ms	≤3ms
命令响应时间	50ms				
串联 ^[6]	最多8台	最多6台	最多3台	最多2台	不建议串联操作
并联	最多10台	最多10台	最多10台	最多10台	最多10台
均流开启电压 ^[7]	40V	50V	120V	200V	250V
效率 (满载)	88%	87%	88%	88%	88%
保护功能	具有过压/过流/过温/过功率/短路保护功能				
输入保险	10A, 125VAC/250VAC, 快速熔断型保险丝				
净重	9.3kg	9.3kg	9.5kg	9.5kg	9.5kg
配件重量	1.0kg	1.0kg	1.0kg	1.0kg	1.0kg
尺寸(WxHxD)	483.0x44.0x531.0 mm				
通讯方式	选项一: RS232/RS485/USB/LAN; 选项二: RS232/RS485/USB/LAN/GPIB				
使用环境	温度 0~40°C, 相对湿度 10%~90%(无冷凝)				
冷却方式	强制风冷				
海拔	2000m				

[1] %output+offset, 输出电压小于 5V 时, offset 为 30mV;

[2] CV模式-额定输出电压 (Vp-p@20MHz, Vrms@1.25MHz);

[3] CC模式 (Arms@1.25MHz), 电流纹波典型值参数标准, 在该机型额定电压满载输出条件下测得, 同时该机型全范围输出电压满载输出时, 电流纹波有效值均在全范围标准范围内;

[4] 环境温度在 0~40°C 内的情况;

[5] 当负载变化从额定输出电流的 10%变化至 90%时, 输出电压恢复到额定输出 0.5%以内的时间。电压设置点从额定输出到 10%至 100%;

[6] 当系统串联电压高于 800V 时, 若使用远程控制, 通讯需隔离;

[7] 均流度说明 $I_e < (I_{av} * 2.5\% + 1)A$, $I_{av} = I_{sum}/n$, I_{sum} 是系统输出总电流, n 是系统中电源总数; 且输出电压需大于表中的均流启动电压后, 才能开启均流功能。

以上所有规格, 如有变更, 恕不另行通知, 请访问官网获取最新产品规格。

● 1000W in 1U

型号	SP150VDC1000W	SP200VDC1000W	SP400VDC1000W	SP600VDC1000W	SP800VDC1000W
输入电压	90~265VAC				
输入频率	47~63Hz				
功率因数	>0.98				
输入功率	1300VA(MAX)	1300VA(MAX)	1300VA(MAX)	1300VA(MAX)	1300VA(MAX)
输出电压范围	0~150V	0~200V	0~400V	0~600V	0~800V
输出电流范围	0~10A	0~8A	0~7.5A	0~5A	0~4A
输出功率范围	0~1000W	0~1000W	0~1000W	0~1000W	0~1000W
电压负载调整率	15mV	15mV	30mV	30mV	40mV
电流负载调整率	10mA	8mA	15mA	10mA	8mA
电压显示分辨率	1mV	1mV	1mV	1mV	1mV
电流显示分辨率	0.2mA	0.1mA	0.1mA	0.1mA	0.1mA
电压程控分辨率	3mV	3mV	8mV	12mV	16mV
电流程控分辨率	1mA	1mA	1mA	1mA	1mA
电压设定值精度 ^[1]	0.1%+15mV	0.1%+15mV	0.05%+100mV	0.05%+150mV	0.05%+200mV
电流设定值精度	0.1%+10mA	0.1%+8mA	0.1%+15mA	0.1%+10mA	0.1%+8mA
电压回读值精度 ^[1]	0.1%+15mV	0.1%+15mV	0.05%+100mV	0.05%+150mV	0.05%+200mV
电流回读值精度	0.1%+10mA	0.1%+8mA	0.1%+15mA	0.1%+10mA	0.1%+8mA
电压纹波 ^[2]	120mVp-p 40mVrms	120mVp-p 40mVrms	350mVp-p 40mVrms	350mVp-p 40mVrms	500mVp-p 60mVrms
电流纹波 ^[3]	40mA (Full Range) 10mA (TYP Value)	40mA (Full Range) 10mA (TYP Value)	25mA (Full Range) 10mA (TYP Value)	25mA (Full Range) 10mA (TYP Value)	25mA (Full Range) 10mA (TYP Value)
线性调整率(电压)	0.02%+8mV	0.02%+8mV	0.02%+20mV	0.02%+30mV	0.02%+40mV
线性调整率(电流)	10mA	30mA	10mA	8mA	10mA
电压温度补偿系数 ^[4]	100ppm/°C				
电流温度补偿系数 ^[4]	150ppm/°C				
DVM 分辨率	1mV	1mV	8mV	12mV	16mV
DVM 精度 ^[1]	0.1%+15mV	0.1%+15mV	0.05%+100mV	0.05%+150mV	0.05%+200mV

型号	SP150VDC1000W	SP200VDC1000W	SP400VDC1000W	SP600VDC1000W	SP800VDC1000W
工作模式	恒压 (CV) / 恒流 (CC)				
远端补偿	4V MAX				
主从控制	具有				
响应 (电压上升)	≤25ms	≤30ms	≤60ms	≤60ms	≤60ms
响应 (电压下降)	≤400ms (空载) ≤25ms (满载)	≤600ms (空载) ≤40ms (满载)	≤800ms (空载) ≤80ms (满载)	≤1200ms (空载) ≤80ms (满载)	≤1200ms (空载) ≤80ms (满载)
负载瞬态响应时间 ^[5]	≤2ms	≤3ms	≤3ms	≤3ms	≤3ms
命令响应时间	50ms				
串联 ^[6]	最多8台	最多6台	最多3台	最多2台	不建议串联操作
并联	最多10台	最多10台	最多10台	最多10台	最多10台
均流开启电压 ^[7]	40V	50V	120V	200V	250V
效率 (满载)	89%	87%	90%	90%	90%
保护功能	具有过压/过流/过温/过功率/短路保护功能				
输入保险	30A, 125VAC/250VAC, 快速熔断型保险丝				
净重	9.3kg	9.3kg	9.5kg	9.5kg	9.5kg
配件重量	1.0kg	1.0kg	1.0kg	1.0kg	1.0kg
尺寸(WxHxD)	483.0x44.0x531.0 mm				
通讯方式	选项一: RS232/RS485/USB/LAN; 选项二: RS232/RS485/USB/LAN/GPIB				
使用环境	温度 0~40°C, 相对湿度 10%~90%(无冷凝)				
冷却方式	强制风冷				
海拔	2000m				

[1] %output+offset, 输出电压小于 5V 时, offset 为 30mV;

[2] CV模式-额定输出电压 (Vp-p@20MHz, Vrms@1.25MHz);

[3] CC模式 (Arms@1.25MHz), 电流纹波典型值参数标准, 在该机型额定电压满载输出条件下测得, 同时该机型全范围输出电压满载输出时, 电流纹波有效值均在全范围标准范围内;

[4] 环境温度在 0~40°C 内的情况;

[5] 当负载变化从额定输出电流的 10% 变化至 90% 时, 输出电压恢复到额定输出 0.5% 以内的时间。电压设置点从额定输出到 10% 至 100%;

[6] 当系统串联电压高于 800V 时, 若使用远程控制, 通讯需隔离;

[7] 均流度说明 $I_e < (I_{av} * 2.5 + 1)A$, $I_{av} = I_{sum}/n$, I_{sum} 是系统输出总电流, n 是系统中电源总数; 且输出电压需大于表中的均流启动电压后, 才能开启均流功能。

以上所有规格, 如有变更, 恕不另行通知, 请访问官网获取最新产品规格。

● 1200W in 1U

型号	SP150VDC1200W	SP200VDC1200W	SP400VDC1200W	SP600VDC1200W	SP800VDC1200W
输入电压	90~265VAC				
输入频率	47~63Hz				
功率因数	>0.98				
输入功率	1500VA(MAX)	1500VA(MAX)	1500VA(MAX)	1500VA(MAX)	1500VA(MAX)
输出电压范围	0~150V	0~200V	0~400V	0~600V	0~800V
输出电流范围	0~10A	0~8A	0~7.5A	0~5A	0~4A
输出功率范围	0~1200W	0~1200W	0~1200W	0~1200W	0~1200W
电压负载调整率	15mV	15mV	30mV	30mV	40mV
电流负载调整率	10mA	8mA	15mA	10mA	8mA
电压显示分辨率	1mV	1mV	1mV	1mV	1mV
电流显示分辨率	0.2mA	0.1mA	0.1mA	0.1mA	0.1mA
电压程控分辨率	3mV	3mV	8mV	12mV	16mV
电流程控分辨率	1mA	1mA	1mA	1mA	1mA
电压设定值精度 ^[1]	0.1%+15mV	0.1%+15mV	0.05%+100mV	0.05%+150mV	0.05%+200mV
电流设定值精度	0.1%+10mA	0.1%+8mA	0.1%+15mA	0.1%+10mA	0.1%+8mA
电压回读值精度 ^[1]	0.1%+15mV	0.1%+15mV	0.05%+100mV	0.05%+150mV	0.05%+200mV
电流回读值精度	0.1%+10mA	0.1%+8mA	0.1%+15mA	0.1%+10mA	0.1%+8mA
电压纹波 ^[2]	120mVp-p 40mVrms	120mVp-p 40mVrms	350mVp-p 40mVrms	350mVp-p 40mVrms	500mVp-p 60mVrms
电流纹波 ^[3]	40mA (Full Range) 10mA (TYP Value)	40mA (Full Range) 10mA (TYP Value)	25mA (Full Range) 10mA (TYP Value)	25mA (Full Range) 10mA (TYP Value)	25mA (Full Range) 10mA (TYP Value)
线性调整率(电压)	0.02%+8mV	0.02%+8mV	0.02%+20mV	0.02%+30mV	0.02%+40mV
线性调整率(电流)	10mA	30mA	10mA	8mA	10mA
电压温度补偿系数 ^[4]	100ppm/°C				
电流温度补偿系数 ^[4]	150ppm/°C				
DVM 分辨率	1mV	1mV	8mV	12mV	16mV
DVM 精度 ^[1]	0.1%+15mV	0.1%+15mV	0.05%+100mV	0.05%+150mV	0.05%+200mV

型号	SP150VDC1200W	SP200VDC1200W	SP400VDC1200W	SP600VDC1200W	SP800VDC1200W
工作模式	恒压 (CV) / 恒流 (CC)				
远端补偿	4V MAX				
主从控制	具有				
响应 (电压上升)	≤25ms	≤30ms	≤60ms	≤60ms	≤60ms
响应 (电压下降)	≤400ms (空载) ≤21ms (满载)	≤600ms (空载) ≤36ms (满载)	≤800ms (空载) ≤72ms (满载)	≤1200ms (空载) ≤72ms (满载)	≤1200ms (空载) ≤60ms (满载)
负载瞬态响应时间 ^[5]	≤2ms	≤3ms	≤3ms	≤3ms	≤3ms
命令响应时间	50ms				
串联 ^[6]	最多8台	最多6台	最多3台	最多2台	不建议串联操作
并联	最多10台	最多10台	最多10台	最多10台	最多10台
均流开启电压 ^[7]	40V	50V	120V	200V	250V
效率 (满载)	89%	90%	90%	90%	90%
保护功能	具有过压/过流/过温/过功率/短路保护功能				
输入保险	30A, 125VAC/250VAC, 快速熔断型保险丝				
净重	9.3kg	9.3kg	9.5kg	9.5kg	9.5kg
配件重量	1.0kg	1.0kg	1.0kg	1.0kg	1.0kg
尺寸(WxHxD)	483.0x44.0x531.0 mm				
通讯方式	选项一: RS232/RS485/USB/LAN; 选项二: RS232/RS485/USB/LAN/GPIB				
使用环境	温度 0~40°C, 相对湿度 10%~90%(无冷凝)				
冷却方式	强制风冷				
海拔	2000m				

[1] %output+offset, 输出电压小于 5V 时, offset 为 30mV;

[2] CV模式-额定输出电压 (Vp-p@20MHz, Vrms@1.25MHz);

[3] CC模式 (Arms@1.25MHz), 电流纹波典型值参数标准, 在该机型额定电压满载输出条件下测得, 同时该机型全范围输出电压满载输出时, 电流纹波有效值均在全范围标准范围内;

[4] 环境温度在 0~40°C 内的情况;

[5] 当负载变化从额定输出电流的 10%变化至 90%时, 输出电压恢复到额定输出 0.5%以内的时间。电压设置点从额定输出到 10%至 100%;

[6] 当系统串联电压高于 800V 时, 若使用远程控制, 通讯需隔离;

[7] 均流度说明 $I_e < (I_{av} * 2.5 + 1)A$, $I_{av} = I_{sum}/n$, I_{sum} 是系统输出总电流, n 是系统中电源总数; 且输出电压需大于表中的均流启动电压后, 才能开启均流功能。

以上所有规格, 如有变更, 恕不另行通知, 请访问官网获取最新产品规格。

● 1500W in 1U

型号	SP150VDC1500W	SP200VDC1500W	SP400VDC1500W	SP600VDC1500W	SP800VDC1500W
输入电压	90~265VAC				
输入频率	47~63Hz				
功率因数	>0.98				
输入功率	1900VA(MAX)	1900VA(MAX)	1900VA(MAX)	1900VA(MAX)	1900VA(MAX)
输出电压范围	0~150V	0~200V	0~400V	0~600V	0~800V
输出电流范围	0~10A	0~8A	0~7.5A	0~5A	0~4A
输出功率范围	0~1500W	0~1500W	0~1500W	0~1500W	0~1500W
电压负载调整率	15mV	15mV	30mV	30mV	40mV
电流负载调整率	10mA	8mA	15mA	10mA	8mA
电压显示分辨率	1mV	1mV	1mV	1mV	1mV
电流显示分辨率	0.2mA	0.1mA	0.1mA	0.1mA	0.1mA
电压程控分辨率	3mV	3mV	8mV	12mV	16mV
电流程控分辨率	1mA	1mA	1mA	1mA	1mA
电压设定值精度 ^[1]	0.1%+15mV	0.1%+15mV	0.05%+100mV	0.05%+150mV	0.05%+200mV
电流设定值精度	0.1%+10mA	0.1%+8mA	0.1%+15mA	0.1%+10mA	0.1%+8mA
电压回读值精度 ^[1]	0.1%+15mV	0.1%+15mV	0.05%+100mV	0.05%+150mV	0.05%+200mV
电流回读值精度	0.1%+10mA	0.1%+8mA	0.1%+15mA	0.1%+10mA	0.1%+8mA
电压纹波 ^[2]	120mVp-p 40mVrms	120mVp-p 40mVrms	350mVp-p 40mVrms	350mVp-p 40mVrms	500mVp-p 60mVrms
电流纹波 ^[3]	40mA (Full Range) 10mA (TYP Value)	40mA (Full Range) 10mA (TYP Value)	25mA (Full Range) 10mA (TYP Value)	25mA (Full Range) 10mA (TYP Value)	25mA (Full Range) 10mA (TYP Value)
线性调整率(电压)	0.02%+8mV	0.02%+8mV	0.02%+20mV	0.02%+30mV	0.02%+40mV
线性调整率(电流)	10mA	30mA	10mA	8mA	10mA
电压温度补偿系数 ^[4]	100ppm/°C				
电流温度补偿系数 ^[4]	150ppm/°C				
DVM 分辨率	1mV	1mV	8mV	12mV	16mV
DVM 精度 ^[1]	0.1%+15mV	0.1%+15mV	0.05%+100mV	0.05%+150mV	0.05%+200mV

型号	SP150VDC1500W	SP200VDC1500W	SP400VDC1500W	SP600VDC1500W	SP800VDC1500W
工作模式	恒压 (CV) / 恒流 (CC)				
远端补偿	4V MAX				
主从控制	具有				
响应 (电压上升)	≤25ms	≤30ms	≤60ms	≤60ms	≤60ms
响应 (电压下降)	≤400ms (空载) ≤18ms (满载)	≤600ms (空载) ≤30ms (满载)	≤800ms (空载) ≤60ms (满载)	≤1200ms (空载) ≤60ms (满载)	≤1200ms (空载) ≤60ms (满载)
负载瞬态响应时间 ^[5]	≤2ms	≤3ms	≤3ms	≤3ms	≤3ms
命令响应时间	50ms				
串联 ^[6]	最多8台	最多6台	最多3台	最多2台	不建议串联操作
并联	最多10台	最多10台	最多10台	最多10台	最多10台
均流开启电压 ^[7]	40V	50V	120V	200V	250V
效率 (满载)	90%	91%	91%	91%	91%
保护功能	具有过压/过流/过温/过功率/短路保护功能				
输入保险	30A, 125VAC/250VAC, 快速熔断型保险丝				
净重	9.3kg	9.3kg	9.5kg	9.5kg	9.5kg
配件重量	1.0kg	1.0kg	1.0kg	1.0kg	1.0kg
尺寸(WxHxD)	483.0x44.0x531.0 mm				
通讯方式	选项一: RS232/RS485/USB/LAN; 选项二: RS232/RS485/USB/LAN/GPIB				
使用环境	温度 0~40°C, 相对湿度 10%~90%(无冷凝)				
冷却方式	强制风冷				
海拔	2000m				

[1] %output+offset, 输出电压小于 5V 时, offset 为 30mV;

[2] CV模式-额定输出电压 (Vp-p@20MHz, Vrms@1.25MHz);

[3] CC模式 (Arms@1.25MHz), 电流纹波典型值参数标准, 在该机型额定电压满载输出条件下测得, 同时该机型全范围输出电压满载输出时, 电流纹波有效值均在全范围标准范围内;

[4] 环境温度在 0~40°C 内的情况;

[5] 当负载变化从额定输出电流的 10% 变化至 90% 时, 输出电压恢复到额定输出 0.5% 以内的时间。电压设置点从额定输出到 10% 至 100%;

[6] 当系统串联电压高于 800V 时, 若使用远程控制, 通讯需隔离;

[7] 均流度说明 $I_e < (I_{av} * 2.5 + 1)A$, $I_{av} = I_{sum} / n$, I_{sum} 是系统输出总电流, n 是系统中电源总数; 且输出电压需大于表中的均流启动电压后, 才能开启均流功能。

以上所有规格, 如有变更, 恕不另行通知, 请访问官网获取最新产品规格。

● 1000W in 2U

型号	SPS20VDC1000W	SPS40VDC1000W	SPS75VDC1000W	SPS120VDC1000W	SPS150VDC1000W
输入电压	90~265VAC				
输入频率	47~63Hz				
功率因数	>0.97	>0.97	>0.97	>0.98	>0.98
输入功率	1400VA(MAX)	1300VA(MAX)	1300VA(MAX)	1300VA(MAX)	1300VA(MAX)
输出电压范围	0~20V	0~40V	0~75V	0~120V	0~150V
输出电流范围	0~200A	0~120A	0~50A	0~40A	0~30A
输出功率范围	0~1000W	0~1000W	0~1000W	0~1000W	0~1000W
电压负载调整率	15mV	15mV	15mV	15mV	15mV
电流负载调整率	200mA	120mA	50mA	40mA	30mA
电压显示分辨率	0.1mV	0.1mV	0.1mV	1mV	1mV
电流显示分辨率	1mA	1mA	0.1mA	0.1mA	0.1mA
电压程控分辨率	1mV	1mV	2mV	3mV	3mV
电流程控分辨率	3mA	3mA	2mA	1mA	1mA
电压设定值精度 ^[1]	0.05%+15mV	0.05%+15mV	0.05%+15mV	0.1%+15mV	0.1%+15mV
电流设定值精度	0.1%+200mA	0.1%+120mA	0.1%+50mA	0.1%+40mA	0.1%+30mA
电压回读值精度 ^[1]	0.05%+15mV	0.05%+15mV	0.05%+15mV	0.1%+15mV	0.1%+15mV
电流回读值精度	0.1%+200mA	0.1%+120mA	0.1%+50mA	0.1%+40mA	0.1%+30mA
电压纹波 ^[2]	40mVp-p 6mVrms	40mVp-p 6mVrms	40mVp-p 6mVrms	80mVp-p 15mVrms	80mVp-p 15mVrms
电流纹波 ^[3]	150mA (Full Range) 40mA (TYP Value)	150mA (Full Range) 20mA (TYP Value)	50mA (Full Range) 10mA (TYP Value)	60mA (Full Range) 10mA (TYP Value)	60mA (Full Range) 10mA (TYP Value)
线性调整率(电压)	0.02%+8mV	0.02%+8mV	0.02%+8mV	0.02%+8mV	0.02%+8mV
线性调整率(电流)	30mA	30mA	30mA	40mA	30mA
电压温度补偿系数 ^[4]	100ppm/°C				
电流温度补偿系数 ^[4]	150ppm/°C				
DVM 分辨率	0.1mV	0.1mV	0.1mV	1mV	1mV
DVM 精度 ^[1]	0.05%+15mV	0.05%+15mV	0.05%+15mV	0.1%+15mV	0.1%+15mV

型号	SPS20VDC1000W	SPS40VDC1000W	SPS75VDC1000W	SPS120VDC1000W	SP150VDC1000W
工作模式	恒压 (CV) / 恒流 (CC)				
远端补偿	4V MAX				
主从控制	具有				
响应 (电压上升)	≤10ms	≤10ms	≤15ms	≤20ms	≤25ms
响应 (电压下降)	≤200ms (空载) ≤20ms (满载)	≤350ms (空载) ≤30ms (满载)	≤450ms (空载) ≤60ms (满载)	≤350ms (空载) ≤30ms (满载)	≤500ms (空载) ≤35ms (满载)
负载瞬态响应时间 ^[5]	≤2ms	≤2ms	≤2ms	≤2ms	≤2ms
命令响应时间	50ms				
串联 ^[6]	最多10台	最多10台	最多10台	最多10台	最多8台
并联	最多10台	最多10台	最多10台	最多10台	最多10台
均流开启电压 ^[7]	12V	12V	20V	30V	40V
效率 (满载)	86%	87%	88%	88%	88%
保护功能	具有过压/过流/过温/过功率/短路保护功能				
输入保险	30A, 125VAC/250VAC, 快速熔断型保险丝				
净重	14.7kg	14.7kg	13.2kg	13.2kg	13.2kg
配件重量	1.0kg	1.0kg	1.0kg	1.0kg	1.0kg
尺寸(WxHxD)	483.0x87.0x626.0 mm		483.0x87.0x581.0 mm		
通讯方式	选项一: RS232/RS485/USB/LAN; 选项二: RS232/RS485/USB/LAN/GPIB				
使用环境	温度 0~40°C, 相对湿度 10%~90%(无冷凝)				
冷却方式	强制风冷				
海拔	2000m				

[1] %output+offset, 输出电压小于 5V 时, offset 为 30mV;

[2] CV模式-额定输出电压 (Vp-p@20MHz, Vrms@1.25MHz);

[3] CC模式 (Arms@1.25MHz), 电流纹波典型值参数标准, 在该机型额定电压满载输出条件下测得, 同时该机型全范围输出电压满载输出时, 电流纹波有效值均在全范围标准范围内;

[4] 环境温度在 0~40°C 内的情况;

[5] 当负载变化从额定输出电流的10%变化至90%时, 输出电压恢复到额定输出0.5%以内的时间。电压设置点从额定输出到10%至100%;

[6] 当系统串联电压高于800V时, 若使用远程控制, 通讯需隔离;

[7] 均流度说明 $I_e < (I_{av} * 2.5 + 1)A$, $I_{av} = I_{sum} / n$, I_{sum} 是系统输出总电流, n 是系统中电源总数; 且输出电压需大于表中的均流启动电压后, 才能开启均流功能。

以上所有规格, 如有变更, 恕不另行通知, 请访问官网获取最新产品规格。

● 1000W in 2U

型号	SPS200VDC1000W	SPS400VDC1000W	SPS600VDC1000W	SPS800VDC1000W
输入电压	90~265VAC			
输入频率	47~63Hz			
功率因数	>0.98	>0.98	>0.98	>0.98
输入功率	1300VA(MAX)	1300VA(MAX)	1300VA(MAX)	1300VA(MAX)
输出电压范围	0~200V	0~400V	0~600V	0~800V
输出电流范围	0~24A	0~15A	0~10A	0~4A
输出功率范围	0~1000W	0~1000W	0~1000W	0~1000W
电压负载调整率	15mV	30mV	30mV	40mV
电流负载调整率	24mA	15mA	10mA	8mA
电压显示分辨率	1mV	1mV	1mV	1mV
电流显示分辨率	0.1mA	0.1mA	0.1mA	0.1mA
电压程控分辨率	4mV	8mV	12mV	16mV
电流量程分辨率	1mA	1mA	1mA	1mA
电压设定值精度 ^[1]	0.1%+15mV	0.05%+100mV	0.05%+150mV	0.05%+200mV
电流设定值精度	0.1%+24mA	0.1%+15mA	0.1%+10mA	0.1%+8mA
电压回读值精度 ^[1]	0.1%+15mV	0.05%+100mV	0.05%+150mV	0.05%+200mV
电流回读值精度	0.1%+24mA	0.1%+15mA	0.1%+10mA	0.1%+8mA
电压纹波 ^[2]	150mVp-p 30mVrms	350mVp-p 40mVrms	350mVp-p 40mVrms	500mVp-p 60mVrms
电流纹波 ^[3]	50mA (Full Range) 20mA (TYP Value)	25mA (Full Range) 10mA (TYP Value)	25mA (Full Range) 10mA (TYP Value)	25mA (Full Range) 10mA (TYP Value)
线性调整率(电压)	0.02%+8mV	0.02%+8mV	0.02%+8mV	0.02%+8mV
线性调整率(电流)	30mA	15mA	15mA	15mA
电压温度补偿系数 ^[4]	100ppm/°C			
电流温度补偿系数 ^[4]	150ppm/°C			
DVM 分辨率	1mV	8mV	12mV	16mV
DVM 精度 ^[1]	0.1%+15mV	0.05%+100mV	0.05%+150mV	0.05%+200mV

型号	SPS200VDC1000W	SPS400VDC1000W	SPS600VDC1000W	SPS800VDC1000W
工作模式	恒压 (CV) / 恒流 (CC)			
远端补偿	4V MAX			
主从控制	具有			
响应 (电压上升)	≤30ms	≤60ms	≤60ms	≤60ms
响应 (电压下降)	≤500ms (空载) ≤35ms (满载)	≤1200ms (空载) ≤110ms (满载)	≤1200ms (空载) ≤110ms (满载)	≤1200ms (空载) ≤110ms (满载)
负载瞬态响应时间 ^[5]	≤2ms	≤3ms	≤3ms	≤3ms
命令响应时间	50ms			
串联 ^[6]	最多6台	最多3台	最多2台	不建议串联使用
并联	最多10台	最多10台	最多10台	最多10台
均流开启电压 ^[7]	50V	120V	200V	250V
效率 (满载)	88%	86%	86%	86%
保护功能	具有过压/过流/过温/过功率/短路保护功能			
输入保险	30A, 125/250VAC, 快速熔断型保险丝	30A, 125VAC/250VAC, 快速熔断型保险丝		
净重	14.7kg	14.7kg	13.2kg	13.2kg
配件重量	1.0kg	1.0kg	1.0kg	1.0kg
尺寸(WxHxD)	483.0x87.0x581.0 mm			
通讯方式	选项一: RS232/RS485/USB/LAN; 选项二: RS232/RS485/USB/LAN/GPIB			
使用环境	温度 0~40°C, 相对湿度 10%~90%(无冷凝)			
冷却方式	强制风冷			
海拔	2000m			

[1] %output+offset, 输出电压小于 5V 时, offset 为 30mV;

[2] CV模式-额定输出电压 (Vp-p@20MHz, Vrms@1.25MHz);

[3] CC模式 (Arms@1.25MHz), 电流纹波典型值参数标准, 在该机型额定电压满载输出条件下测得, 同时该机型全范围输出电压满载输出时, 电流纹波有效值均在全范围标准范围内;

[4] 环境温度在 0~40°C 内的情况;

[5] 当负载变化从额定输出电流的10%变化至90%时, 输出电压恢复到额定输出0.5%以内的时间。电压设置点从额定输出到10%至100%;

[6] 当系统串联电压高于800V时, 若使用远程控制, 通讯需隔离;

[7] 均流度说明 $I_e < (I_{av} * 2.5\% + 1)A$, $I_{av} = I_{sum}/n$, I_{sum} 是系统输出总电流, n 是系统中电源总数; 且输出电压需大于表中的均流启动电压后, 才能开启均流功能。

以上所有规格, 如有变更, 恕不另行通知, 请访问官网获取最新产品规格。

● 2000W in 2U

型号	SP20VDC2000W	SP40VDC2000W	SP75VDC2000W	SP80VDC2000W	SP120VDC2000W
输入电压	190~265VAC				
输入频率	47~63Hz				
功率因数	>0.98				
输入功率	2400VA(MAX)	2400VA(MAX)	2400VA(MAX)	2400VA(MAX)	2400VA(MAX)
输出电压范围	0~20V	0~40V	0~75V	0~80V	0~120V
输出电流范围	0~200A	0~120A	0~50A	0~60A	0~40A
输出功率范围	0~2000W	0~2000W	0~2000W	0~2000W	0~2000W
电压负载调整率	15mV	15mV	15mV	15mV	15mV
电流负载调整率	200mA	120mA	50mA	60mA	40mA
电压显示分辨率	0.1mV	0.1mV	0.1mV	0.1mV	1mV
电流显示分辨率	1mA	1mA	0.1mA	0.1mA	0.1mA
电压程控分辨率	1mV	1mV	2mV	2mV	3mV
电流程控分辨率	3mA	3mA	2mA	2mA	1mA
电压设定值精度 ^[1]	0.05%+15mV	0.05%+15mV	0.05%+15mV	0.1%+15mV	0.1%+15mV
电流设定值精度	0.1%+200mA	0.1%+120mA	0.1%+50mA	0.1%+60mA	0.1%+40mA
电压回读值精度 ^[1]	0.05%+15mV	0.05%+15mV	0.05%+15mV	0.1%+15mV	0.1%+15mV
电流回读值精度	0.1%+200mA	0.1%+120mA	0.1%+50mA	0.1%+60mA	0.1%+40mA
电压纹波 ^[2]	40mVp-p 6mVrms	40mVp-p 6mVrms	40mVp-p 6mVrms	40mVp-p 6mVrms	80mVp-p 15mVrms
电流纹波 ^[3]	150mA (Full Range) 40mA (TYP Value)	150mA (Full Range) 20mA (TYP Value)	50mA (Full Range) 10mA (TYP Value)	60mA (Full Range) 10mA (TYP Value)	60mA (Full Range) 10mA (TYP Value)
线性调整率(电压)	0.01%+8mV	0.01%+8mV	0.01%+8mV	0.01%+8mV	0.02%+8mV
线性调整率(电流)	30mA	30mA	30mA	30mA	30mA
电压温度补偿系数 ^[4]	100ppm/°C				
电流温度补偿系数 ^[4]	150ppm/°C				
DVM 分辨率	0.1mV	0.1mV	0.1mV	0.1mV	1mV
DVM 精度 ^[1]	0.05%+15mV	0.05%+15mV	0.05%+15mV	0.05%+15mV	0.1%+15mV

型号	SP20VDC2000W	SP40VDC2000W	SP75VDC2000W	SP80VDC2000W	SP120VDC2000W
工作模式	恒压 (CV) / 恒流 (CC)				
远端补偿	4V MAX				
主从控制	具有				
响应 (电压上升)	≤10ms	≤10ms	≤15ms	≤15ms	≤20ms
响应 (电压下降)	≤200ms (空载) ≤15ms (满载)	≤350ms (空载) ≤18ms (满载)	≤450ms (空载) ≤30ms (满载)	≤450ms (空载) ≤30ms (满载)	≤350ms (空载) ≤27ms (满载)
负载瞬态响应时间 ^[5]	≤2ms	≤2ms	≤2ms	≤3ms	≤3ms
命令响应时间	50ms				
串联 ^[6]	最多10台	最多10台	最多10台	最多10台	最多8台
并联	最多10台	最多10台	最多10台	最多10台	最多10台
均流开启电压 ^[7]	12V	12V	20V	20V	30V
效率 (满载)	86%	88%	88%	89%	89%
保护功能	具有过压/过流/过温/过功率/短路保护功能				
输入保险	30A, 125VAC/250VAC, 快速熔断型保险丝				
净重	14.7kg	14.7kg	13.2kg	13.2kg	13.2kg
配件重量	1.0kg	1.0kg	1.0kg	1.0kg	1.0kg
尺寸(WxHxD)	483.0x87.0x626.0 mm		483.0x87.0x581.0 mm		
通讯方式	选项一: RS232/RS485/USB/LAN; 选项二: RS232/RS485/USB/LAN/GPIB				
使用环境	温度 0~40°C, 相对湿度 10%~90%(无冷凝)				
冷却方式	强制风冷				
海拔	2000m				

[1] %output+offset, 输出电压小于 5V 时, offset 为 30mV;

[2] CV模式-额定输出电压 (Vp-p@20MHz, Vrms@1.25MHz);

[3] CC模式 (Arms@1.25MHz), 电流纹波典型值参数标准, 在该机型额定电压满载输出条件下测得, 同时该机型全范围输出电压满载输出时, 电流纹波有效值均在全范围标准范围内;

[4] 环境温度在 0~40°C 内的情况;

[5] 当负载变化从额定输出电流的10%变化至90%时, 输出电压恢复到额定输出0.5%以内的时间。电压设置点从额定输出到10%至100%;

[6] 当系统串联电压高于800V时, 若使用远程控制, 通讯需隔离;

[7] 均流度说明 $I_e < (I_{av} * 2.5\% + 1)A$, $I_{av} = I_{sum}/n$, I_{sum} 是系统输出总电流, n 是系统中电源总数; 且输出电压需大于表中的均流启动电压后, 才能开启均流功能。

以上所有规格, 如有变更, 恕不另行通知, 请访问官网获取最新产品规格。

● 2000W in 2U

型号	SP150VDC2000W	SP200VDC2000W	SP400VDC2000W	SP600VDC2000W	SP800VDC2000W
输入电压	190~265VAC				
输入频率	47~63Hz				
功率因数	>0.98				
输入功率	2400VA(MAX)	2400VA(MAX)	2400VA(MAX)	2400VA(MAX)	2400VA(MAX)
输出电压范围	0~150V	0~200V	0~400V	0~600V	0~800V
输出电流范围	0~30A	0~24A	0~15A	0~10A	0~7.5A
输出功率范围	0~2000W	0~2000W	0~2000W	0~2000W	0~2000W
电压负载调整率	15mV	15mV	15mV	30mV	40mV
电流负载调整率	30mA	24mA	15mA	30mA	20mA
电压显示分辨率	1mV	1mV	1mV	1mV	1mV
电流显示分辨率	0.1mA	0.1mA	0.1mA	0.1mA	0.1mA
电压程控分辨率	3mV	4mV	8mV	12mV	16mV
电流程控分辨率	1mA	1mA	1mA	1mA	1mA
电压设定值精度 ^[1]	0.1%+15mV	0.1%+15mV	0.05%+100mV	0.05%+150mV	0.05%+200mV
电流设定值精度	0.1%+30mA	0.1%+24mA	0.1%+15mA	0.1%+10mA	0.1%+10mA
电压回读值精度 ^[1]	0.1%+15mV	0.1%+15mV	0.05%+100mV	0.05%+150mV	0.05%+200mV
电流回读值精度	0.1%+30mA	0.1%+24mA	0.1%+15mA	0.1%+10mA	0.1%+10mA
电压纹波 ^[2]	40mVp-p 6mVrms	40mVp-p 6mVrms	350mVp-p 40mVrms	350mVp-p 40mVrms	500mVp-p 60mVrms
电流纹波 ^[3]	60mA (Full Range) 10mA (TYP Value)	50mA (Full Range) 20mA (TYP Value)	25mA (Full Range) 10mA (TYP Value)	25mA (Full Range) 10mA (TYP Value)	25mA (Full Range) 10mA (TYP Value)
线性调整率(电压)	0.02%+8mV	0.02%+8mV	0.01%+20mV	0.01%+30mV	0.01%+40mV
线性调整率(电流)	30mA	30mA	24mA	15mA	20mA
电压温度补偿系数 ^[4]	100ppm/°C				
电流温度补偿系数 ^[4]	150ppm/°C				
DVM 分辨率	0.1mV	0.1mV	0.1mV	0.1mV	1mV
DVM 精度 ^[1]	0.1%+15mV	0.1%+15mV	0.05%+100mV	0.05%+150mV	0.05%+200mV

型号	SP150VDC2000W	SP200VDC2000W	SP400VDC2000W	SP600VDC2000W	SP800VDC2000W
工作模式	恒压 (CV) / 恒流 (CC)				
远端补偿	5V MAX				
主从控制	具有				
响应 (电压上升)	≤25ms	≤30ms	≤60ms	≤60ms	≤60ms
响应 (电压下降)	≤500ms (空载) ≤36ms (满载)	≤500ms (空载) ≤30ms (满载)	≤1200ms (空载) ≤90ms (满载)	≤1200ms (空载) ≤90ms (满载)	≤1200ms (空载) ≤90ms (满载)
负载瞬态响应时间 ^[5]	≤3ms	≤3ms	≤3ms	≤3ms	≤3ms
命令响应时间	50ms				
串联 ^[6]	最多8台	最多6台	最多3台	最多2台	不建议串联操作
并联	最多10台	最多10台	最多10台	最多10台	最多10台
均流开启电压 ^[7]	40V	50V	120V	200V	250V
效率 (满载)	90%	90%	91%	91%	91%
保护功能	具有过压/过流/过温/过功率/短路保护功能				
输入保险	30A, 125VAC/250VAC, 快速熔断型保险丝		20A, 125VAC/250VAC, 快速熔断型保险丝		
净重	13.2kg	13.2kg	14.7kg	14.7kg	14.7kg
配件重量	1.0kg	1.0kg	1.0kg	1.0kg	1.0kg
尺寸(WxHxD)	483.0x87.0x581.0 mm				
通讯方式	选项一: RS232/RS485/USB/LAN; 选项二: RS232/RS485/USB/LAN/GPIB				
使用环境	温度 0~40°C, 相对湿度 10%~90%(无冷凝)				
冷却方式	强制风冷				
海拔	2000m				

[1] %output+offset, 输出电压小于 5V 时, offset 为 30mV;

[2] CV模式-额定输出电压 (Vp-p@20MHz, Vrms@1.25MHz);

[3] CC模式 (Arms@1.25MHz), 电流纹波典型值参数标准, 在该机型额定电压满载输出条件下测得, 同时该机型全范围输出电压满载输出时, 电流纹波有效值均在全范围标准范围内;

[4] 环境温度在 0~40°C 内的情况;

[5] 当负载变化从额定输出电流的 10%变化至 90%时, 输出电压恢复到额定输出 0.5%以内的时间。电压设置点从额定输出到 10%至 100%;

[6] 当系统串联电压高于 800V 时, 若使用远程控制, 通讯需隔离;

[7] 均流度说明 $I_e < (I_{av} * 2.5% + 1)A$, $I_{av} = I_{sum}/n$, I_{sum} 是系统输出总电流, n 是系统中电源总数; 且输出电压需大于表中的均流启动电压后, 才能开启均流功能。

以上所有规格, 如有变更, 恕不另行通知, 请访问官网获取最新产品规格。

● 3000W in 2U

型号	SP20VDC3000W	SP32VDC3000W	SP40VDC3000W	SP75VDC3000W	SP80VDC3000W
输入电压	190~265VAC				
输入频率	47~63Hz				
功率因数	>0.98				
输入功率	2400VA(MAX)	2400VA(MAX)	2400VA(MAX)	2400VA(MAX)	2400VA(MAX)
输出电压范围	0~20V	0~32V	0~40V	0~75V	0~80V
输出电流范围	0~200A	0~120A	0~120A	0~50A	0~60A
输出功率范围	0~3000W	0~3000W	0~3000W	0~3000W	0~3000W
电压负载调整率	15mV	15mV	15mV	15mV	15mV
电流负载调整率	200mA	120mA	120mA	50mA	60mA
电压显示分辨率	0.1mV	0.1mV	0.1mV	0.1mV	0.1mV
电流显示分辨率	1mA	1mA	1mA	0.1mA	0.1mA
电压程控分辨率	1mV	1mV	1mV	2mV	2mV
电流程控分辨率	3mA	3mA	2mA	2mA	2mA
电压设定值精度 ^[1]	0.05%+15mV	0.05%+15mV	0.05%+15mV	0.1%+15mV	0.1%+15mV
电流设定值精度	0.1%+200mA	0.1%+120mA	0.1%+120mA	0.1%+50mA	0.1%+60mA
电压回读值精度 ^[1]	0.05%+15mV	0.05%+15mV	0.05%+15mV	0.1%+15mV	0.1%+15mV
电流回读值精度	0.1%+200mA	0.1%+120mA	0.1%+120mA	0.1%+50mA	0.1%+60mA
电压纹波 ^[2]	40mVp-p 6mVrms	40mVp-p 6mVrms	40mVp-p 6mVrms	40mVp-p 6mVrms	40mVp-p 6mVrms
电流纹波 ^[3]	300mA (Full Range) 80mA (TYP Value)	150mA (Full Range) 20mA (TYP Value)	150mA (Full Range) 20mA (TYP Value)	50mA (Full Range) 10mA (TYP Value)	50mA (Full Range) 10mA (TYP Value)
线性调整率(电压)	0.01%+8mV	0.01%+8mV	0.01%+8mV	0.01%+8mV	0.01%+8mV
线性调整率(电流)	30mA	30mA	30mA	30mA	30mA
电压温度补偿系数 ^[4]	100ppm/°C				
电流温度补偿系数 ^[4]	150ppm/°C				
DVM 分辨率	0.1mV	0.1mV	0.1mV	0.1mV	0.1mV
DVM 精度 ^[1]	0.05%+15mV	0.05%+15mV	0.05%+15mV	0.05%+15mV	0.05%+15mV

型号	SP20VDC3000W	SP32VDC3000W	SP40VDC3000W	SP75VDC3000W	SP80VDC3000W
工作模式	恒压 (CV) / 恒流 (CC)				
远端补偿	4V MAX	4V MAX	4V MAX	5V MAX	4V MAX
主从控制	具有				
响应 (电压上升)	≤10ms	≤10ms	≤10ms	≤15ms	≤15ms
响应 (电压下降)	≤300ms (空载) ≤12ms (满载)	≤350ms (空载) ≤12ms (满载)	≤350ms (空载) ≤30ms (满载)	≤450ms (空载) ≤25ms (满载)	≤450ms (空载) ≤30ms (满载)
负载瞬态响应时间 ^[5]	≤2ms	≤2ms	≤2ms	≤2ms	≤2ms
命令响应时间	50ms				
串联 ^[6]	最多10台	最多10台	最多10台	最多10台	最多10台
并联	最多10台	最多10台	最多10台	最多10台	最多10台
均流开启电压 ^[7]	12V	12V	12V	20V	20V
效率 (满载)	86%	86%	88%	91%	91%
保护功能	具有过压/过流/过温/过功率/短路保护功能				
输入保险	40A, 125VAC/250VAC, 快速熔断型保险丝				
净重	14.7kg	14.7kg	14.7kg	13.2kg	13.2kg
配件重量	1.0kg	1.0kg	1.0kg	1.0kg	1.0kg
尺寸(WxHxD)	483.0x87.0x626.0 mm			483.0x87.0x581.0 mm	
通讯方式	选项一: RS232/RS485/USB/LAN; 选项二: RS232/RS485/USB/LAN/GPIB				
使用环境	温度 0~40°C, 相对湿度 10%~90%(无冷凝)				
冷却方式	强制风冷				
海拔	2000m				

[1] %output+offset, 输出电压小于 5V 时, offset 为 30mV;

[2] CV模式-额定输出电压 (Vp-p@20MHz, Vrms@1.25MHz);

[3] CC模式 (Arms@1.25MHz), 电流纹波典型值参数标准, 在该机型额定电压满载输出条件下测得, 同时该机型全范围输出电压满载输出时, 电流纹波有效值均在全范围标准范围内;

[4] 环境温度在 0~40°C 内的情况;

[5] 当负载变化从额定输出电流的10%变化至90%时, 输出电压恢复到额定输出0.5%以内的时间。电压设置点从额定输出到10%至100%;

[6] 当系统串联电压高于800V时, 若使用远程控制, 通讯需隔离;

[7] 均流度说明 $I_e < (I_{av} * 2.5\% + 1)A$, $I_{av} = I_{sum}/n$, I_{sum} 是系统输出总电流, n 是系统中电源总数; 且输出电压需大于表中的均流启动电压后, 才能开启均流功能。

以上所有规格, 如有变更, 恕不另行通知, 请访问官网获取最新产品规格。

● 3000W in 2U

型号	SP120VDC3000W	SP150VDC3000W	SP200VDC3000W	SP400VDC3000W	SP600VDC3000W
输入电压	190~265VAC				
输入频率	47~63Hz				
功率因数	>0.98				
输入功率	3400VA(MAX)	3400VA(MAX)	3400VA(MAX)	3400VA(MAX)	3400VA(MAX)
输出电压范围	0~120V	0~150V	0~200V	0~400V	0~600V
输出电流范围	0~40A	0~30A	0~24A	0~15A	0~10A
输出功率范围	0~3000W	0~3000W	0~3000W	0~3000W	0~3000W
电压负载调整率	15mV	15mV	15mV	30mV	30mV
电流负载调整率	40mA	30mA	24mA	15mA	10mA
电压显示分辨率	1mV	1mV	1mV	1mV	1mV
电流显示分辨率	0.1mA	0.1mA	0.1mA	0.1mA	0.1mA
电压程控分辨率	3mV	3mV	4mV	8mV	12mV
电流程控分辨率	1mA	1mA	1mA	1mA	1mA
电压设定值精度 ^[1]	0.1%+15mV	0.1%+15mV	0.1%+15mV	0.05%+100mV	0.05%+150mV
电流设定值精度	0.1%+40mA	0.1%+30mA	0.1%+24mA	0.1%+15mA	0.1%+10mA
电压回读值精度 ^[1]	0.1%+15mV	0.1%+15mV	0.1%+15mV	0.05%+100mV	0.05%+150mV
电流回读值精度	0.1%+40mA	0.1%+30mA	0.1%+24mA	0.1%+15mA	0.1%+10mA
电压纹波 ^[2]	80mVp-p 15mVrms	80mVp-p 15mVrms	150mVp-p 30mVrms	350mVp-p 40mVrms	350mVp-p 40mVrms
电流纹波 ^[3]	60mA (Full Range) 10mA (TYP Value)	60mA (Full Range) 10mA (TYP Value)	50mA (Full Range) 20mA (TYP Value)	25mA (Full Range) 10mA (TYP Value)	25mA (Full Range) 10mA (TYP Value)
线性调整率(电压)	0.02%+8mV	0.02%+8mV	0.02%+8mV	0.01%+20mV	0.01%+30mV
线性调整率(电流)	30mA	30mA	30mA	24mA	15mA
电压温度补偿系数 ^[4]	100ppm/°C				
电流温度补偿系数 ^[4]	150ppm/°C				
DVM 分辨率	1mV	1mV	1mV	8mV	12mV
DVM 精度 ^[1]	0.1%+15mV	0.1%+15mV	0.1%+15mV	0.05%+100mV	0.05%+150mV

型号	SP120VDC3000W	SP150VDC3000W	SP200VDC3000W	SP400VDC3000W	SP600VDC3000W
工作模式	恒压 (CV) / 恒流 (CC)				
远端补偿	5V MAX				
主从控制	具有				
响应 (电压上升)	≤20ms	≤25ms	≤30ms	≤60ms	≤60ms
响应 (电压下降)	≤350ms (空载) ≤21ms (满载)	≤500ms (空载) ≤25ms (满载)	≤500ms (空载) ≤25ms (满载)	≤1200ms (空载) ≤75ms (满载)	≤1200ms (空载) ≤75ms (满载)
负载瞬态响应时间 ^[5]	≤2ms	≤2.5ms	≤3ms	≤3ms	≤3ms
命令响应时间	50ms				
串联 ^[6]	最多10台	最多8台	最多6台	最多3台	最多2台
并联	最多10台	最多10台	最多10台	最多10台	最多10台
均流开启电压 ^[7]	30V	40V	50V	120V	200V
效率 (满载)	91%	92%	91%	91%	91%
保护功能	具有过压/过流/过温/过功率/短路保护功能				
输入保险	40A, 125VAC/250VAC, 快速熔断型保险丝			30A, 125VAC/250VAC, 快速熔断型保险丝	
净重	13.2kg	13.2kg	13.2kg	14.7kg	14.7kg
配件重量	1.0kg	1.0kg	1.0kg	1.0kg	1.0kg
尺寸(WxHxD)	483.0x87.0x581.0 mm				
通讯方式	选项一: RS232/RS485/USB/LAN; 选项二: RS232/RS485/USB/LAN/GPIB				
使用环境	温度 0~40°C, 相对湿度 10%~90%(无冷凝)				
冷却方式	强制风冷				
海拔	2000m				

[1] %output+offset, 输出电压小于 5V 时, offset 为 30mV;

[2] CV模式-额定输出电压 (Vp-p@20MHz, Vrms@1.25MHz);

[3] CC模式 (Arms@1.25MHz), 电流纹波典型值参数标准, 在该机型额定电压满载输出条件下测得, 同时该机型全范围输出电压满载输出时, 电流纹波有效值均在全范围标准范围内;

[4] 环境温度在 0~40°C 内的情况;

[5] 当负载变化从额定输出电流的 10%变化至 90%时, 输出电压恢复到额定输出 0.5%以内的时间。电压设置点从额定输出到 10%至 100%;

[6] 当系统串联电压高于 800V 时, 若使用远程控制, 通讯需隔离;

[7] 均流度说明 $I_e < (I_{av} * 2.5% + 1)A$, $I_{av} = I_{sum}/n$, I_{sum} 是系统输出总电流, n 是系统中电源总数; 且输出电压需大于表中的均流启动电压后, 才能开启均流功能。

以上所有规格, 如有变更, 恕不另行通知, 请访问官网获取最新产品规格。

● 4000W in 2U

型号	SP800VDC3000W	SP20VDC4000W	SP40VDC4000W	SP75VDC4000W	SP120VDC4000W
输入电压	190~265VAC				
输入频率	47~63Hz				
功率因数	>0.98				
输入功率	3400VA(MAX)	4500VA(MAX)	4500VA(MAX)	4500VA(MAX)	4500VA(MAX)
输出电压范围	0~800V	0~20V	0~40V	0~75V	0~120V
输出电流范围	0~10A	0~200A	0~120A	0~60A	0~40A
输出功率范围	0~3000W	0~4000W	0~4000W	0~4000W	0~4000W
电压负载调整率	40mV	15mV	15mV	15mV	15mV
电流负载调整率	20mA	200mA	120mA	60mA	40mA
电压显示分辨率	1mV	0.1mV	0.1mV	0.1mV	1mV
电流显示分辨率	0.1mA	1mA	1mA	0.1mA	0.1mA
电压程控分辨率	16mV	1mV	1mV	2mV	3mV
电流程控分辨率	1mA	3mA	3mA	2mA	1mA
电压设定值精度 ^[1]	0.05%+200mV	0.05%+15mV	0.05%+15mV	0.1%+15mV	0.1%+15mV
电流设定值精度	0.1%+20mA	0.1%+200mA	0.1%+120mA	0.1%+60mA	0.1%+40mA
电压回读值精度 ^[1]	0.05%+200mV	0.05%+15mV	0.05%+15mV	0.1%+15mV	0.1%+15mV
电流回读值精度	0.1%+20mA	0.1%+200mA	0.1%+120mA	0.1%+60mA	0.1%+40mA
电压纹波 ^[2]	500mVp-p 60mVrms	40mVp-p 6mVrms	40mVp-p 6mVrms	40mVp-p 8mVrms	80mVp-p 15mVrms
电流纹波 ^[3]	25mA (Full Range) 10mA (TYP Value)	300mA (Full Range) 80mA (TYP Value)	150mA (Full Range) 20mA (TYP Value)	60mA (Full Range) 10mA (TYP Value)	60mA (Full Range) 10mA (TYP Value)
线性调整率(电压)	0.01%+40mV	0.01%+8mV	0.01%+8mV	0.01%+8mV	0.02%+8mV
线性调整率(电流)	30mA	30mA	30mA	30mA	30mA
电压温度补偿系数 ^[4]	100ppm/°C				
电流温度补偿系数 ^[4]	150ppm/°C				
DVM 分辨率	16mV	0.1mV	0.1mV	0.1mV	1mV
DVM 精度 ^[1]	0.05%+200mV	0.05%+15mV	0.05%+15mV	0.05%+15mV	0.1%+15mV

型号	SP800VDC3000W	SP20VDC4000W	SP40VDC4000W	SP75VDC4000W	SP120VDC4000W
工作模式	恒压 (CV) / 恒流 (CC)				
远端补偿	5V MAX	4V MAX	4V MAX	5V MAX	5V MAX
主从控制	具有				
响应 (电压上升)	≤60ms	≤15ms	≤15ms	≤15ms	≤20ms
响应 (电压下降)	≤1200ms (空载) ≤75ms (满载)	≤300ms (空载) ≤10ms (满载)	≤350ms (空载) ≤10ms (满载)	≤450ms (空载) ≤20ms (满载)	≤350ms (空载) ≤18ms (满载)
负载瞬态响应时间 ^[5]	≤3ms	≤2ms	≤2ms	≤2ms	≤2ms
命令响应时间	50ms				
串联 ^[6]	不建议串联操作	最多10台	最多10台	最多10台	最多10台
并联	最多10台	最多10台	最多10台	最多10台	最多10台
均流开启电压 ^[7]	250V	5V	12V	20V	30V
效率 (满载)	91%	90%	91%	91%	92%
保护功能	具有过压/过流/过温/过功率/短路保护功能				
输入保险	30A, 125/250VAC, 快速熔断型保险丝	40A, 125VAC/250VAC, 快速熔断型保险丝			
净重	14.7kg	14.7kg	14.7kg	13.2kg	13.2kg
配件重量	1.0kg	1.0kg	1.0kg	1.0kg	1.0kg
尺寸(WxHxD)	483.0x87.0x581.0 mm	483.0x87.0x626.0 mm		483.0x87.0x581.0 mm	
通讯方式	选项一: RS232/RS485/USB/LAN; 选项二: RS232/RS485/USB/LAN/GPIB				
使用环境	温度 0~40°C, 相对湿度 10%~90%(无冷凝)				
冷却方式	强制风冷				
海拔	2000m				

[1] %output+offset, 输出电压小于 5V 时, offset 为 30mV;

[2] CV模式-额定输出电压 (Vp-p@20MHz, Vrms@1.25MHz);

[3] CC模式 (Arms@1.25MHz), 电流纹波典型值参数标准, 在该机型额定电压满载输出条件下测得, 同时该机型全范围输出电压满载输出时, 电流纹波有效值均在全范围标准范围内;

[4] 环境温度在 0~40°C 内的情况;

[5] 当负载变化从额定输出电流的 10%变化至 90%时, 输出电压恢复到额定输出 0.5%以内的时间。电压设置点从额定输出到 10%至 100%;

[6] 当系统串联电压高于 800V 时, 若使用远程控制, 通讯需隔离;

[7] 均流度说明 $I_e < (I_{av} * 2.5% + 1)A$, $I_{av} = I_{sum}/n$, I_{sum} 是系统输出总电流, n 是系统中电源总数; 且输出电压需大于表中的均流启动电压后, 才能开启均流功能。

以上所有规格, 如有变更, 恕不另行通知, 请访问官网获取最新产品规格。

● 4000W in 2U

型号	SP150VDC4000W	SP200VDC4000W	SP400VDC4000W	SP600VDC4000W	SP800VDC4000W
输入电压	190~265VAC				
输入频率	47~63Hz				
功率因数	>0.98				
输入功率	4500VA(MAX)	4500VA(MAX)	4500VA(MAX)	4500VA(MAX)	4500VA(MAX)
输出电压范围	0~150V	0~200V	0~400V	0~600V	0~800V
输出电流范围	0~30A	0~24A	0~15A	0~10A	0~7.5A
输出功率范围	0~4000W	0~4000W	0~4000W	0~4000W	0~4000W
电压负载调整率	15mV	15mV	15mV	30mV	40mV
电流负载调整率	30mA	24mA	15mA	10mA	20mA
电压显示分辨率	1mV	1mV	1mV	1mV	1mV
电流显示分辨率	0.1mA	0.1mA	0.1mA	0.1mA	0.1mA
电压程控分辨率	3mV	4mV	8mV	12mV	16mV
电流程控分辨率	1mA	1mA	1mA	1mA	1mA
电压设定值精度 ^[1]	0.1%+15mV	0.1%+15mV	0.05%+100mV	0.05%+150mV	0.05%+200mV
电流设定值精度	0.1%+30mA	0.1%+24mA	0.1%+15mA	0.1%+10mA	0.1%+10mA
电压回读值精度 ^[1]	0.1%+15mV	0.1%+15mV	0.05%+100mV	0.05%+150mV	0.05%+200mV
电流回读值精度	0.1%+30mA	0.1%+24mA	0.1%+15mA	0.1%+10mA	0.1%+10mA
电压纹波 ^[2]	80mVp-p 15mVrms	150mVp-p 30mVrms	350mVp-p 40mVrms	350mVp-p 40mVrms	500mVp-p 60mVrms
电流纹波 ^[3]	60mA (Full Range) 10mA (TYP Value)	50mA (Full Range) 20mA (TYP Value)	25mA (Full Range) 10mA (TYP Value)	25mA (Full Range) 10mA (TYP Value)	25mA (Full Range) 10mA (TYP Value)
线性调整率(电压)	0.02%+8mV	0.02%+8mV	0.01%+20mV	0.01%+30mV	0.01%+40mV
线性调整率(电流)	30mA	30mA	24mA	15mA	20mA
电压温度补偿系数 ^[4]	100ppm/°C				
电流温度补偿系数 ^[4]	150ppm/°C				
DVM 分辨率	1mV	1mV	8mV	12mV	12mV
DVM 精度 ^[1]	0.1%+15mV	0.1%+15mV	0.05%+100mV	0.05%+150mV	0.05%+200mV

型号	SP150VDC4000W	SP200VDC4000W	SP400VDC4000W	SP600VDC4000W	SP800VDC4000W
工作模式	恒压 (CV) / 恒流 (CC)				
远端补偿	5V MAX	5V MAX	5V MAX	5V MAX	5V MAX
主从控制	具有				
响应 (电压上升)	≤30ms	≤30ms	≤60ms	≤60ms	≤60ms
响应 (电压下降)	≤500ms (空载) ≤20ms (满载)	≤500ms (空载) ≤20ms (满载)	≤1200ms (空载) ≤60ms (满载)	≤1200ms (空载) ≤60ms (满载)	≤1200ms (空载) ≤60ms (满载)
负载瞬态响应时间 ^[5]	≤2.5ms	≤3ms	≤3ms	≤3ms	≤3ms
命令响应时间	50ms				
串联 ^[6]	最多8台	最多6台	最多3台	最多2台	不建议串联操作
并联	最多10台	最多10台	最多10台	最多10台	最多10台
均流开启电压 ^[7]	40V	50V	120V	200V	250V
效率 (满载)	93%	92%	92%	92%	92%
保护功能	具有过压/过流/过温/过功率/短路保护功能				
输入保险	40A, 125VAC/250VAC, 快速熔断型保险丝				
净重	13.2kg	13.2kg	14.7kg	14.7kg	14.7kg
配件重量	1.0kg	1.0kg	1.0kg	1.0kg	1.0kg
尺寸(WxHxD)	483.0x87.0x581.0 mm				
通讯方式	选项一: RS232/RS485/USB/LAN; 选项二: RS232/RS485/USB/LAN/GPIB				
使用环境	温度 0~40°C, 相对湿度 10%~90%(无冷凝)				
冷却方式	强制风冷				
海拔	2000m				

[1] %output+offset, 输出电压小于 5V 时, offset 为 30mV;

[2] CV模式-额定输出电压 (Vp-p@20MHz, Vrms@1.25MHz);

[3] CC模式 (Arms@1.25MHz), 电流纹波典型值参数标准, 在该机型额定电压满载输出条件下测得, 同时该机型全范围输出电压满载输出时, 电流纹波有效值均在全范围标准范围内;

[4] 环境温度在 0~40°C 内的情况;

[5] 当负载变化从额定输出电流的 10%变化至 90%时, 输出电压恢复到额定输出 0.5%以内的时间。电压设置点从额定输出到 10%至 100%;

[6] 当系统串联电压高于 800V 时, 若使用远程控制, 通讯需隔离;

[7] 均流度说明 $I_e < (I_{av} * 2.5\% + 1)A$, $I_{av} = I_{sum}/n$, I_{sum} 是系统输出总电流, n 是系统中电源总数; 且输出电压需大于表中的均流启动电压后, 才能开启均流功能。

以上所有规格, 如有变更, 恕不另行通知, 请访问官网获取最新产品规格。

Appendix B Web Server介绍

1. 连接方式

此系列电源内置Web Server，支持本地监控以及远程监控。

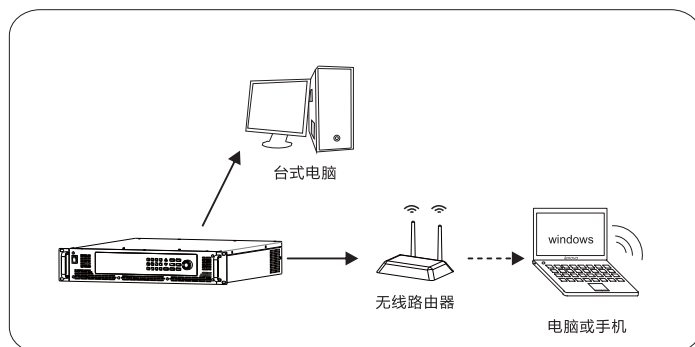

上图作为本地监控的连接示意，监控时电源以及电脑的IP地址在需同一网段，借助无线路由还可以实现笔记本或者手机与电源的通讯，在浏览器内输入电源的IP地址即可访问，并对其监控。

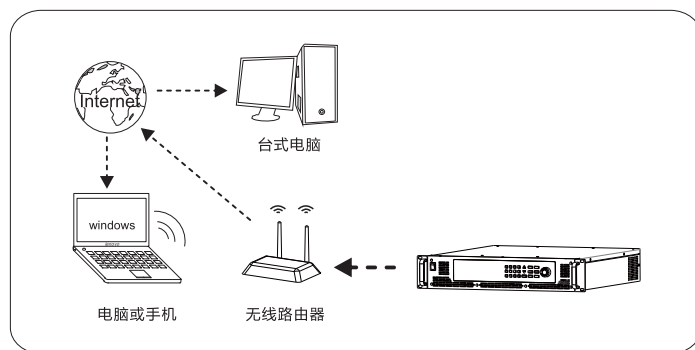

上图作为远程监控的连接示意，无线路由连接至Internet，通过无线路由的映射，可实现远程监控。

2. 监控界面

2.1 Login界面

打开浏览器界面，输入电源的IP地址即可进入欢迎界面。

Copyright © APM Technologies (Dongguan) Co., Ltd All Right Reserved
Add: #7, Link Information Industry Park, Shullianshan Road, Nancheng, Dongguan, Guangdong, China
Tel: +86 769 2202 8588

User ID为Admin，Password为123456，登陆成功后，进入Home界面。

2.2 Home界面

Vset	12.0000 V	Vmeas	12.0000 V
Iset	25.0000 A	Imeas	25.0000 A
DVM	12.0000 V	Power	240.000 W
CV/CC	CV	ON/OFF	ON <input checked="" type="radio"/> OFF <input type="radio"/>

Warning

Vset V

Iset A

Save

Copyright © APM Technologies (Dongguan) Co., Ltd All Right Reserved
Add: #7, Link Information Industry Park, Shullianshan Road, Nancheng, Dongguan, Guangdong, China
Tel: +86 769 2202 8588

Home界面可进行电源电压/电流的设定&测量，电源运行状态的显示，以及控制电源输出的开关。

2.3 Control界面

Control界面可进行电源保护值、蜂鸣器开关、均流功能、快速下降功能、电源开机状态等参数的设定。

2.4 System Setting界面

System Setting界面读取电源的基本信息，修改LAN通讯参数，以及重设密码。

2.5 Product Line界面

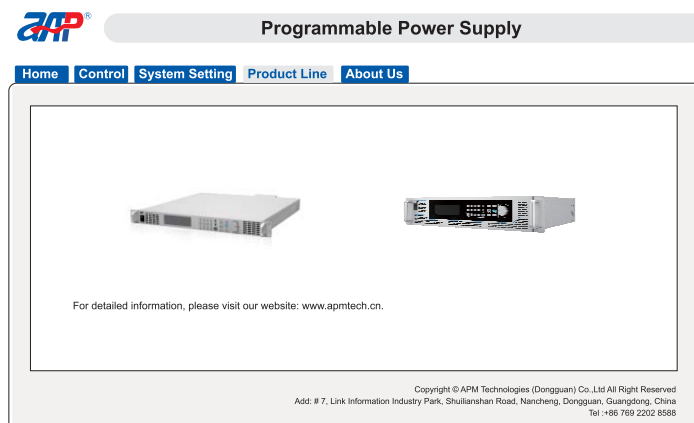

Product Line界面介绍全天科技的电源产品线。

2.6 About Us界面

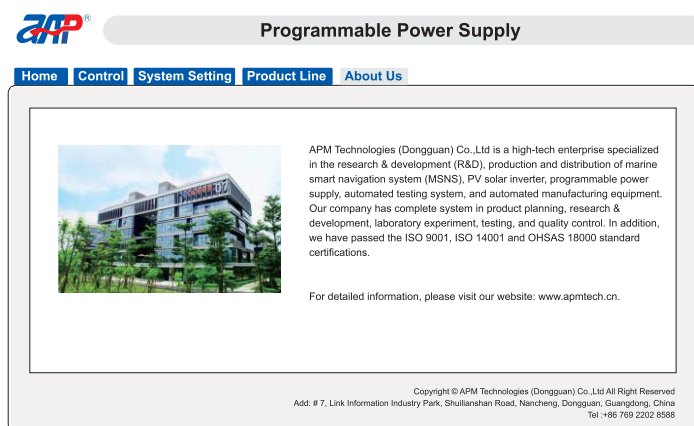

About Us界面为全天科技的简介。

Appendix C 质保声明

承蒙您惠购全天自动化能源科技(东莞)有限公司(以下文中简称“全天科技”)可编程直流电源产品, 谨致谢意! 为了您更好地使用全天科技的产品, 全天科技为您提供下述标准质保服务, 请您仔细阅读以下说明。

此质保卡适用于全天科技可编程直流电源产品。

您的销售商为您提供的品质保证及服务不受此质保卡影响, 但我司对销售商的质量保证及服务不做任何承诺和保证。

▶ 质保期限

1. 全天科技可编程直流电源产品(以下简称“产品”)的质保期限为2年, 或参考相应的销售合同条款执行。
2. 质保期限不因产品或部件的更换而延长或重新计算, 您仍可在原质保期限内继续享受质保服务。

▶ 质保条款

1. 如果产品在质保期限内发生故障, 请将质保卡和购机发票的扫描件发送到全天科技客服邮箱, 全天科技将根据实际情况为您提供维修或更换整机的服务, 无论哪种方式, 全天科技都将为您提供最好最专业的服务;
2. 全天科技在提供质保服务中更换下来的所有部件归全天科技所有。如全天科技为您更换了产品或部件, 请将更换下来的旧产品或部件交由销售商统一保管, 全天科技将在一定时间内取回旧产品或部件。

▶ 责任豁免

以下情况全天科技有权不予提供质保服务:

1. 整机已超出质保期;
2. 无法提供经销商开具的购机发票, 并且无法确定为本公司产品;
3. 无全天科技标识的产品, 或产品上的铭牌不完整或非清晰可见;
4. 产品上无防拆标签, 或防拆标签破损;
5. 随机配件不在质保范围内;
6. 非全天科技授权的人员或用户自行拆装、维修;
7. 未按使用说明书要求的操作方法所造成的产品故障或损坏;

8. 超出使用说明书的非常恶劣的环境运行造成的产品故障或损坏；
9. 因使用非标准或非本公司部件或软件导致的机器故障或损坏；
10. 因自然灾害等不可抗力(包括但不限于雷击、火灾洪水等)原因造成的故障或损坏；
11. 因意外或人为原因(包括但不限于运输、储存、接入不合适的电压、操作失误等)导致的故障或损坏；
12. 对功能没有影响的外观不良缺陷。

以上，若客户要求进行维修服务，经本公司服务机构判定后可提供有偿服务。

► 免责声明

1. 全天科技不对由于设备故障引起的直接或间接地功能问题进行补偿，因非法操作或非品质问题而造成运行中的资料的丢失不负责，请使用者自己妥善保管资料。非因产品品质问题造成的人身伤害及财产损失，全天科技不予赔偿。全天科技在任何其他场合提出或表达的质保承诺如与以上条款有冲突，则以本质保卡所述条款为准。
2. 为保障您的质保权益，请您联系全天科技的客服，注册您的产品质保资讯。
3. 只有全天科技有权修改以上质保内容，任何贸易商和经销商均无权对全天科技提供的质保卡做出任何更改，或代表全天科技表达任何观点和行为。全天科技保留最终解释权。
4. 产品一旦出现问题，请及时与距您最近的经销商联系，以便为您提供相应的服务。
5. 若全天科技技术人员到现场为您提供服务，请出示您的质保卡，由全天科技人员填写。

► 补充说明

1. 请保留完整的附表和购机发票，作为质保依据。
2. 请在每次维修前提供附表供维修人员填写。
3. 请妥善保管附表，丢失后不补发。

附表

产品信息表		
分销商	公司名称	
	联系人	
	电话	
	地址	
用户信息表		
用户	姓名	
	电话	
	地址	
	传真	
	邮箱	
产品故障信息表		
产品型号		
产品序号		
质保日期		
故障日期	签名	故障描述及解决方案

贴序列号处





Add: # 7, Link Information Industry Park, Shuilianshan
Road, Nancheng, Dongguan, Guangdong, China
Tel: +86 769 2202 8588 E-mail: MK@apmtech.cn
Fax: +86 769 2202 6770 Web: www.apmtech.cn